



# Brand Guidelines

Version 28 | Update: 01.31.2025

# Table of Contents

Message from the President	3	Event Collateral	44	External Facilities	86
Our Brand and Overview	4	Event Partnerships	45	Signage: Interior	88
The COM Logo	6	Letterhead	46	Wayfinding: Plaques	89
Clear space	9	Address	47	Wayfinding Directionals	99
College Name	11	Email Signature	49	Wayfinding: Vinyl Lettering	112
Brand Colors	12	Business Cards	50	Murals	113
Logos	13	Name Tags	51	Temporary Notices	114
The Brand Box	21	PowerPoint Templates	52	Unique Applications	115
Logo Usage in Materials	23	Promotional Items	53	Signage: Vehicular	117
College Department Logos	25	Indoor Retractable	60	Brand Campaign	119
Mascot Logo	26	Signage & Design	61	Clubs & Organizations	122
Meta Major Logos	31	All Facilities	62	A Cohesive Experience	124
Other Logos	32	The Onion Philosophy	63		
Advertising Types	34	Wayfinding System	64		
Institution vs. Event	35	Navigational Arrows	65		
Non-Discrimination	36	Signage: Exterior	69		
Fonts	37	Building Lettering	70		
Logo Usage	40	Wayfinding	73		
Brand Imagery	43	Hours of Operation	85		

# A Message from the President

Dear Friends of College of the Mainland,

It is our privilege to commend to you our Brand Guidelines. In the pages that follow, you will discover the meaning and intent of COM's brand identity, and why its consistent application is important for College of the Mainland's future.



The brand identity represents the rich heritage of College of the Mainland, and expresses it with distinction. This visible and unique "signature" conveys to the world that COM is a college with a mission committed to excellence and diversity and focused on the higher educational needs of its students, faculty and staff. These guidelines will help every individual member of the COM family, as well as vendors, apply this brand identity consistently and accurately.

It is the responsibility of the Executive Director of Marketing and Public Affairs to oversee and coordinate the application of our brand, thereby assuring the College and Board of Trustees that these standards are applied correctly and appropriately in publications, advertisements, digital media, signage and other areas. Please familiarize yourself with these guidelines. Should you have a question about the application of this system, need help appropriating elements of the system, or need authorization for products and elements bearing the college logo and brand, please contact the Office of Marketing and Public Affairs.

Sincerely,

A handwritten signature in blue ink, which appears to read "Warren Nichols". The signature is fluid and cursive, written over a light blue horizontal line.

Dr. Warren Nichols,  
President

# More than just a logo

College of the Mainland's brand encompasses more than just a logo. It is the friendly, caring people. It is our facilities and their appearance. It is the on hold message, the website, or an ad. It is the process of enrolling. It is the experience a student has online and on campus. Our brand is ultimately the public's perception at any single touch point.

Our brand is who we are.

# Overview

The COM logo is a visual symbol representing the COM brand which collectively encompasses all aspects of our image, our mission, our quality and who we are. These Brand Guidelines express the rich heritage of College of the Mainland conveying to the world that COM is committed to excellence and diversity and is focused on the higher educational needs of its students.

These guidelines will help all members of the COM family, including vendors, apply this brand identity system consistently and accurately.

The Marketing and Public Affairs Office is charged with the responsibility to oversee and coordinate the application of the brand identity system, thereby assuring the Board of Trustees that these standards are applied correctly and appropriately in publications, advertisements and products used throughout the college and its learning centers.

## **Purpose of these Brand Guidelines**

These Brand Guidelines provide specifications for the use and presentation of the COM logos, Horizons, Texas Stars and the Fighting Ducks mascot logo. This manual includes examples of how and how not to use the logos in a variety of materials and situations. It is important that these standards are applied when COM identities are incorporated across all communications to create familiarity and maintain consistency and continuity. The COM logo must be treated consistently to visually embody a cornerstone that supports the COM message and identity across the entire organization and throughout its service area, in all college programs, services and activities.

## **Core Standards of Usage**

The Branding Guidelines apply to all print and digital college communications both for internal and commercial use

including, but not limited to website, social media, publications, documentation, invitations, signage, fliers, promo pieces, and advertising materials. The common standards are adherence to typography, style, color, proportion, placement, clear space and size relationships determined per application.

In all situations where guidelines have not been previously determined, the Office of Marketing and Public Affairs must be contacted for policy regarding usage. All uses whether print or digital of the College of the Mainland logo, abbreviated letters "COM", mascot logo, other official college logos and use of the written form of "College of the Mainland" must receive brand approval from the Marketing department before printing, apparel production, emailing or any other form of distribution.

## **College District and Service Area**

College of the Mainland's taxing district consists of residents in Dickinson, Hitchcock, La Marque, Texas City, and Santa Fe school districts. Service areas include League City, Friendswood, Kemah, Bacliff and San Leon.

## **For More Information**

The Office of Marketing and Public Affairs monitors and maintains the COM brand identity. Questions about this Brand Guidelines manual, brand approvals, use of the logo and other visual identification elements, should be addressed to the Marketing and Public Affairs Office at 409-933-8437 or [brandapproval@com.edu](mailto:brandapproval@com.edu).

# The COM Logo

# Logo

Old logos (out of service)



Correct logo



The COM brand architecture has moved away from all uses of the torch to a bold recognizable design of integrity and success.

The new logo, as defined in these guidelines, will be displayed on the college's communications including social media, website, publications, advertisements, posters, fliers, vehicles, stickers, billboards, television, banners, promotional materials, signage, invitations, thank you's, applications, reports, employee gear, clothing, presentations sponsored events and partnership materials.

The COM logo should not be used on unofficial college material including unapproved events, unofficial partnerships or business associations.

Please note: The correct COM logo should only contain one registered mark. Please see page 22 for more details.

# Logo

COM stacked logo



COM horizontal logo extended



COM horizontal logotype



The College of the Mainland logotype is made up of two separate type faces. Sabon is used for the large letters "COM" and the words "College" and "Mainland." Galliard is used for the words "of" and "the."

These fonts are reserved strictly for the logo and should not be used as other content on the page, or other application type to preserve the integrity of the logo.

The official College of the Mainland logo exists in three formats:

A stacked version and two variations of the horizontal version.

The stacked version must be the combination of the large COM letter emblem and the logotype, the full college name, below it as one unit.

The horizontal logo options offer an extended variation that begins with the COM letters separated by a vertical line, and followed by the logotype all as one unit, or the logotype variation on its own.

Each official format of the logo should contain only one registration mark after the words "College of the Mainland."

Determining the use of a stacked format versus a horizontal format will be based on the canvas area where the logo is to be applied taking all specifications provided in this Brand Guideline manual and design principles into consideration.



# Logo: Clear Space

Minimum clear space designated by outer green line = 1/7th (14.29%) of logo width (total width illustrated by blue line) or width of the "Co" in the spelled out college name.

## Vertical stacked logo format

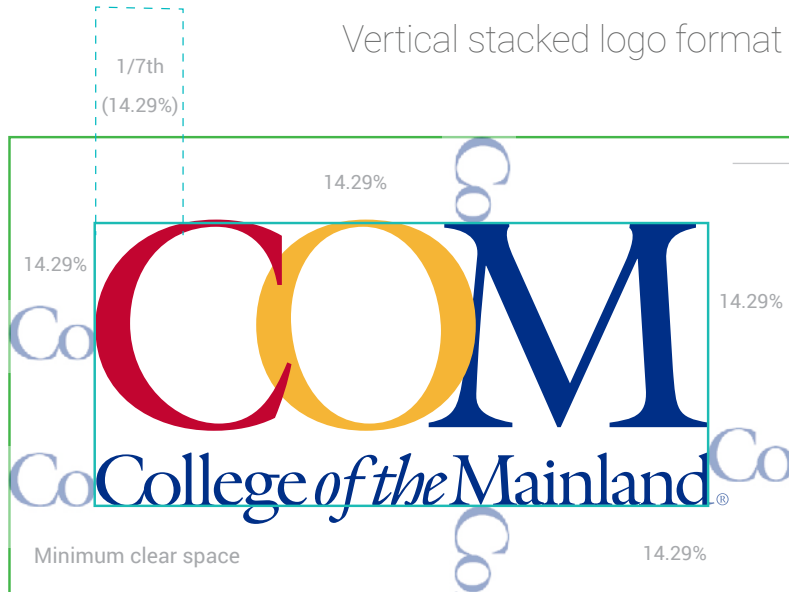

Minimum logo clear space shown between logo's edge and outer green line. More clear space is encouraged when possible, but it should not be less.



Example of COM logo above with **incorrect clear space** around logo within the rectangular shape.



**Correct minimum clear space**  
Example of COM logo above, centered in a box displaying the **correct minimum clear space** and positioning required around all four sides.

## Horizontal logo format



To visually offset the descenders and balance of clear space, a small "a" is used upright to determine minimum spacing on the bottom below the large "COM". However, the small "a" should be turned on its side to determine minimum spacing along the top, left and right.

Minimum clear space is required around the logo and must be maintained to preserve the integrity of the brand. Clear space is the distance from the logo's edge to the outer green line. Nothing should invade the logo's clear space.

Note: Clear space defined here is a minimum requirement and, in most cases, more clear space is encouraged and should grow extensively with logo's enlargement.

### Stacked logo

In the vertical stacked logo the minimum clear space requirement is measured as 1/7th of the logo's perceived visual width (the length of the letters "Co" taken from the logotype). The logo's total perceived visual width is derived from the logotype "College of the Mainland" in the official stacked logo. It begins at the curvature of the "C" and extends to the right edge of the vertical ascender in the letter "d". Due to the visual weight of the COM in the stacked logo, the perceived width does not include the small extending serif from the letter "d" or the registration mark.

### Horizontal logo

In the horizontal logo the minimum clear space is created using the lowercase letter "a" from the logotype's official horizontal logo. The "a" is rotated on its side for left, top, and right against the "COM's" "C" and "M", and the lowercase "d's" serif as shown on the left. The "a" is right side up for the bottom margin against the "COM" "M's" base serif. This is to create a visual balance within the minimum clear space.

## Logo: Clear Space (Larger Areas)

Official COM Flag



Clear space

While minimum clear space is required around the logo, larger amounts of clear space around the logo increase the respect of the brand. As the logo's size increases so should the proportion of clear space.

This example portrays the COM flag utilizing clear space as a means to create a presence that is distinguished. Clear space creates focus, integrity and richness allowing the logo to breath visually.

## College Name

# College of the Mainland

# COM

The college name and acronym should never be written in fonts that could be described as script, handwritten, cute, child-like, cartoonish or other fonts displaying heavy decorative effects without Marketing's prior approval.

In addition to the COM logo, the official name of the college, "College of the Mainland" and its corresponding acronym "COM", are key identifiers of the institution.

These key identifiers equally represent all that our college embodies from our resilient goal of student success to our relentless mission for excellence. The quality and consistency of all written, visual, and audio contexts where the college name appears are a critical area of importance as they contribute significantly to the college's brand perception.

In written instances, the complete name "College of the Mainland" should be used on any first reference with subsequent references written as "COM" (with no periods). Do not use any other variation such as "C.O.M." or "COTM."



To preserve the integrity of the college brand, please refrain using "COM" as part of a cute play on words (i.e., "COMing", "COMplete", etc).

All external and public facing usage of the college name, college acronym, or official college logos require a brand approval from the Office of Marketing and Public Affairs before use, printing or distribution.

Use of the written college name requires brand approval on items including, but not limited to: fliers, printed or physical materials, promotional items both giveaway or for sale, club logos, signage, college department initiatives, media relations, vehicles, events, and advertisements.

# Brand Colors: Primary and Secondary

## Primary color palette

		
“COM Blue” PANTONE 287 C	“COM Red” PANTONE 200 C	“COM Yellow” PANTONE 143 C
CMYK: 100, 87, 20, 11	CMYK: 16, 100, 86, 7	CMYK: 2, 32, 91, 0
RGB: 0, 47, 135	RGB: 194, 4, 48	RGB: 246, 180, 54
HEX: 002F87	HEX: C20430	HEX: F6B436

“COM Blue” is considered the single dominant color for COM.

“COM Red” is also dominant in use cases such as the brand box.

“COM Yellow” is typically not used as a dominant color and often is eliminated or used in an assistive manner. In the core color logo, the “O” of COM that references the word “of” is written in yellow. In the same way “of” is an assistive word, yellow is an assistive color.

The primary official brand color palette for College of the Mainland consists of COM red, yellow and blue as defined on the left.

“COM Blue” is considered the dominant color visually with “COM Red” being used frequently for vibrancy. “COM Yellow” typically should not be used as a dominant color but can play visually assistive roles if needed.

The secondary color palette, used in conjunction with the COM logo, may be used to enhance and create a more robust and vibrant external message. It introduces flexibility in conveying tone and expression while strengthening and elevating the COM brand.

Secondary colors may not replace full or partial colors in the official logo without approval from the Office of Marketing and Public Affairs.

## Secondary color palette

PANTONE: 3005 C C: 100 M: 46 Y: 2 K: 0	PANTONE: Orange 021 C C: 0 M: 82 Y: 100 K: 0	PANTONE: 7731 C C: 85 M: 23 Y: 93 K: 9	PANTONE: 7540 C C: 69 M: 59 Y: 52 K: 33
PANTONE: 2995 C C: 73 M: 16 Y: 0 K: 0	PANTONE: 715 C C: 0 M: 54 Y: 93 K: 0	PANTONE: 360 C C: 61 M: 0 Y: 95 K: 0	PANTONE: Cool Gray 6 C C: 36 M: 29 Y: 28 K: 0
PANTONE: 297 C C: 52 M: 4 Y: 3 K: 0	PANTONE: 120 C C: 1 M: 12 Y: 72 K: 0	PANTONE: 367 C C: 40 M: 0 Y: 81 K: 0	PANTONE: Cool Gray 3 C C: 21 M: 16 Y: 17 K: 0
PANTONE: 317 C C: 29 M: 0 Y: 11 K: 0	PANTONE: 600 C C: 7 M: 2 Y: 48 K: 0	PANTONE: 7485 C C: 19 M: 4 Y: 30 K: 0	PANTONE: Cool Gray 1 C C: 13 M: 10 Y: 12 K: 0

Black should be registration black:  
CMYK: 0, 0, 0, 100.

The standard body text color for COM publications is a dark gray using the values noted below. Black should never be used.

Hex: #4D4D4F  
CMYK: 66, 59, 55, 36

# Logo Centering: Visual width and height

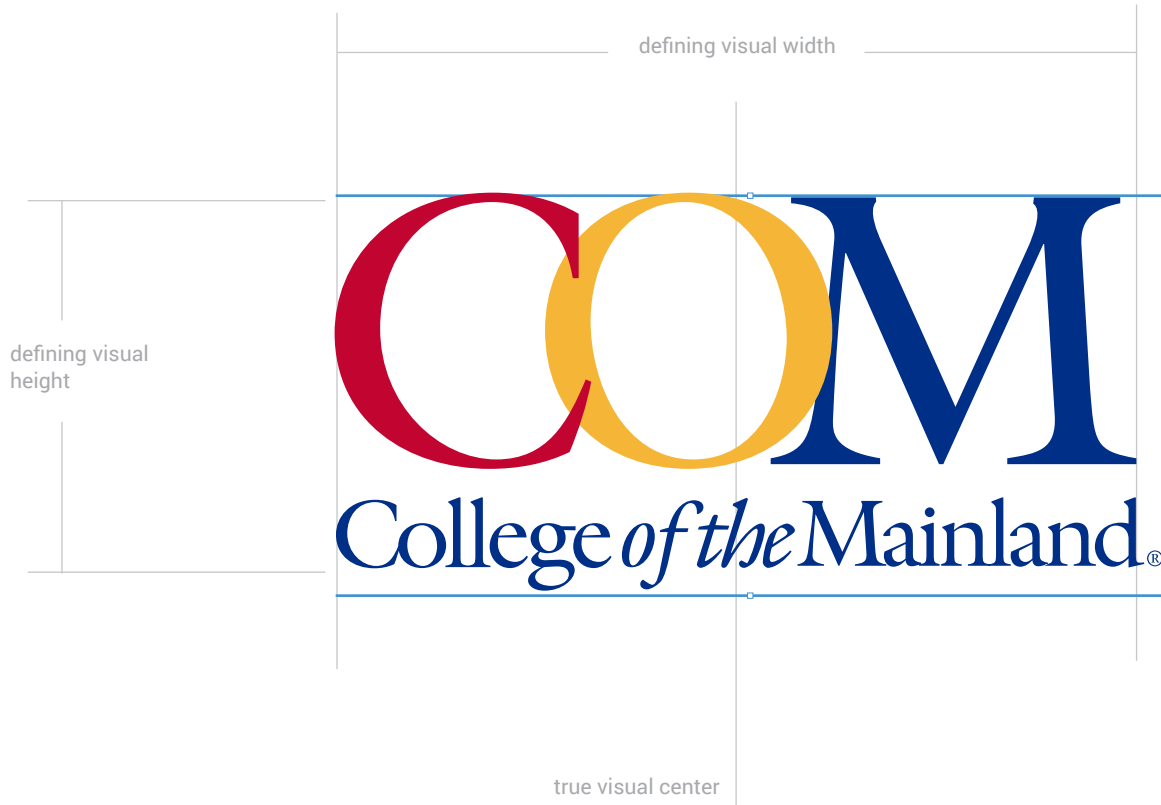

It is important to note the true visual center of the COM logo when centering of the logo is required. It is not as simple as aligning object selection marks (see blue lines on the left).

The defining width to center horizontally is the “C’s” edge on the left. On the right the defining line should follow the serif of the “M” and down outside the ascender of the small “d”. The tailing serif from the small “d” and the registration mark should not be included as part of the visual measurement due to their visual insignificance.

The defining height used to center vertically extends from the top of the large “M’s” serifs to the base of the smaller “M’s” serif.

# Logo: Minimum Size

Vertical stacked logo format

Minimum display width:  
1 inch

Proportional



Please note:

All logos less than 3 inches wide should **remove** the small registration mark.

Horizontal logo format

Minimum display width:  
1.5 inches

Proportional



The minimum size of the College of the Mainland logos should always maintain readability first and foremost. These guidelines apply to the COM Foundation logo as well.

Minimum sizes as described here should only be used in limited circumstances, primarily for promotional items and digital web banner advertising.

Minimum sizes may be larger for uses such as clothing embroidery due to production quality limitations.

Please note, all logos less than 3 inches wide should not include a registration mark.

# Logo: Color (Stacked Logo)

Tri-color official logo (stacked)



Other official color variations for stacked logo in blue and red used in limited circumstances.



The COM logo is in essence a silhouette filled with color that represents the college and various initiatives.

The logo may be used in the color variations seen here in addition to black, white and grays later described.

## Color logos

The tri-color logo consisting of red, yellow and blue is the official logo, but must only be used over a white or extremely light background no darker than 15% black or similar color to maintain legibility. This logo should not be used when the logo colors do not compliment or work well with other colors present in the design.

The stacked COM logo may also be used in all "COM Blue" or all "COM Red."

Caution and consideration should be exercised using an all red logo as not to portray unintentional aggression.

The Marketing department, in its sole discretion, may use other colors in special circumstances.

# Logo: (Stacked) Black, White, Gray

Black (stacked)



Reverse (stacked)



Black notched logo.

Black, white and logos used in shades of gray are designed differently with a small notch cut out of the "C" overlap. The color logo does not have this cut out notch.

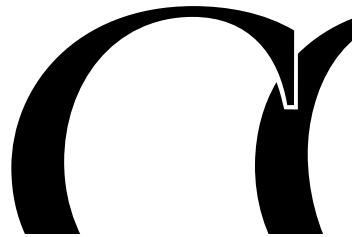

White notched logo.



Standard gray: 65% black



C: 0      R: 119      HEX: 77787B  
 M: 0      G: 120  
 Y: 0      B: 123  
 K: 65

Alternative official stacked logo grays

#f1f2f2	5% black	#b1b3b6	35% black	#77787B	65% black
#dcdde	15% black	#9d9fa2	45% black	#636466	75% black
#c7c8ca	25% black	#8a8c8e	55% black	#4d4d4f	85% black

COM stacked logos that are black, white or gray must use the notched version where the "C" is cutout. This applies to the COM Foundation logo as well.

## Black logo

The notched black logo variation can be used over 100% white backgrounds and other values up to 55% black and similar background colors.

## White logo

The notched white logo can be used over 100% black backgrounds and other values down to 30% black and similar colors.

## Gray logos

Gray stacked logos should be a variation of the notched black logo using pure black ranging in ten percent increments from 5% to 85% used only with contrasting backgrounds for legibility.

When placing the College of the Mainland logo on a background or photograph, always ensure the surrounding area is neutral in appearance, absent of a busy texture and ultimately allows for the logo to be visually clear and legible.



# Logo: Color (Horizontal)

tri-color official logo (horizontal)



College of the Mainland®

Alternative approved color variations for horizontal logo  
in blue and red used in limited circumstances.



**Symmetry:** For design instances where symmetry is needed, or there are limitations within a horizontal space, the logotype may be displayed without the COM slash.

College of the Mainland®

The COM logo is a silhouette filled with color to represent the college identity. The horizontal logo may appear in two forms, with or without the official letters “COM” and corresponding vertical line as shown on the left.

The horizontal logo may be used in the color variations seen here in addition to black, white and grays later described.

## Horizontal logo

The tri-color logo consisting of red, yellow and blue is the official logo, but must only be used over a white or extremely light background no darker than 15% black or similar color to maintain legibility. This logo should not be used when the logo colors do not compliment or work well with other colors present in the design.

The horizontal COM logo may also be used in all “COM Blue” or all “COM Red.”

Caution and consideration should be exercised using an all red logo as not to portray unintentional aggression.

The Marketing department, in its sole discretion, may use other colors in special circumstances.

The horizontal logo without the “COM” and vertical line is specifically used in scenarios where the presence of the “COM slash” disrupts a symmetrical visual balance primarily in center-aligned arrangements (symmetrical building entrances, diplomas, posters, etc).

# Logo: (Horizontal) Black, White, Gray

Black (horizontal)

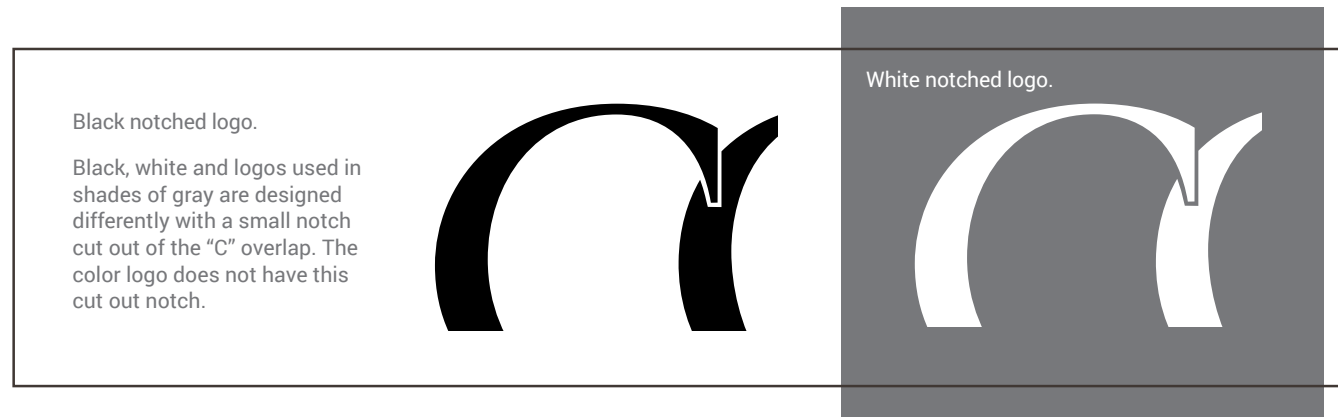

Standard gray: 65% black



C: 0      R: 119      HEX: 77787B  
 M: 0      G: 120  
 Y: 0      B: 123  
 K: 65

## Alternative official horizontal logo grays

#f1f2f2	5% black	#b1b3b6	35% black	#77787B	65% black
#dcdde	15% black	#9d9fa2	45% black	#636466	75% black
#c7c8ca	25% black	#8a8c8e	55% black	#4d4d4f	85% black

The COM logo can be used in one of 4 color designs based on the application.

### Color logo

This is the official logo style, but must only be used over a white or extremely light background no darker than 15% value of black or similar color to maintain legibility. This logo should not be used when logo colors do not compliment other colors present in the overall design.

### Black logo

The notched black logo variation can be used over 100% white backgrounds and other values up to 55% black and similar background colors.

### Gray logos

Gray logos should be a variation of the notched black logo used in 10% increments of pure black from 5% to 85% used only with contrasting backgrounds for legibility.

### White logo

The notched white logo can be used over 100% black backgrounds and other values down to 30% black and similar colors.

When placing the College of the Mainland logo on a background or photograph, always ensure the surrounding area is neutral in appearance and ultimately allows for the logo to be visually clear and legible.

Logo: Color Green



PANTONE 360 C

C: 61  
M: 0  
Y: 95  
K: 0

R: 110  
G: 190  
B: 76

HEX: 6EBE4C

The green COM logo is reserved for **environmentally-related usage only.**

Appropriate use case examples include Recycling, Adopt-a-Beach, Sustainability, Earth Day, Save the Planet or other measures to beautify, protect life, animals, nature and our environment.

This logo should only be used over a white background. If simple gray background elements are present, such as the leaf background seen here, the background should not exceed 17% opacity.

## Logo: Color Pink



PANTONE: 212 C

C: 0  
M: 83  
Y: 5  
K: 0

R: 245  
G: 81  
B: 151

HEX: F55197

*College of the Mainland*®

The pink COM logo is reserved for **Breast Cancer related usage only** and exhibits COM's awareness and support of this cause.

This pink logo should only be used over a white background or light gray not to exceed 10% value of black.

# Logo: The Brand Box

Spacing on the right and left should be the width of the small letters "Coll". See lines below for measurement points.

## The COM Brand Box

COM Brand Box Examples:



Spacing above the logo in the box should be the height of the large letter "C" in "COM"

Spacing below the logo in the box should be the height of the large letter "C" in "COM"



Brand box uses include: Flyers, posters, PowerPoint, video and more.

Lower portions of the brand box may be overlapped by a person's head or other element to create depth. However, no portion of the COM logo itself may be obstructed.



The Brand Box is a design approach to create visual structure for COM's logo usage in communications drawing distinction, focus and clarity for immediate brand recognition.

The Brand Box is reserved solely for the stacked COM logo and should be used in Institutional-based advertising only (no campus event-based advertising).

The Brand Box should display a color from the approved color palette that visually enhances and supports the overall design. The COM logo should maintain sufficient contrast to the selected box color.

The Brand Box **must always appear anchored** to either the top (left or right), or in limited circumstances either the bottom (left or right), or center (top or bottom) in a design. When used in left or right positioning, the brand box should never be placed flush into a corner, but rather indented so it appears as a tab-like, banner element. Please see examples on this page.

The Brand Box's standard width for an 8.5x11 flier is either 2.75in wide or 4in wide depending on layout and content constraints. Please note however, the Brand Box's overall scale may be adjusted if needed, but should avoid appearing overly large.

# Logo: The Brand Box (COM Foundation)

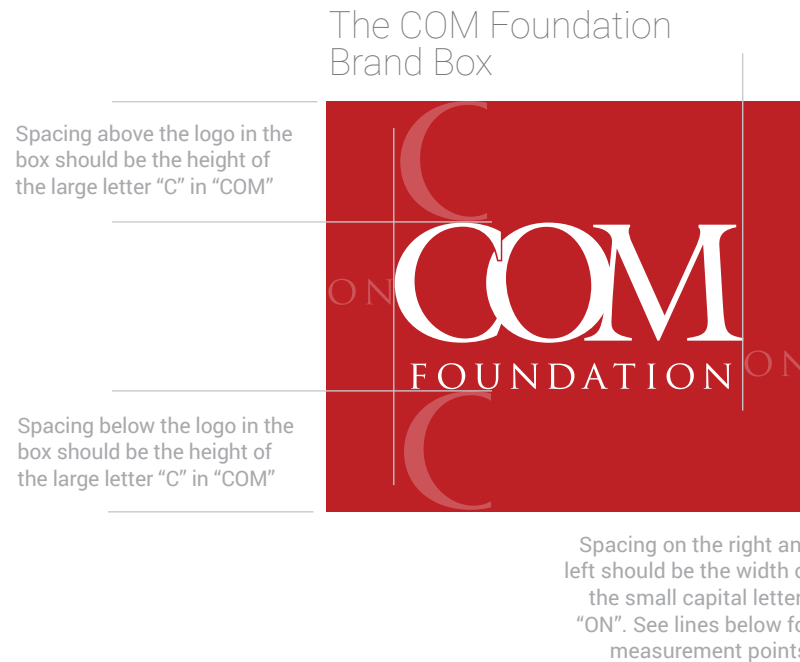

COM Foundation Brand box uses include: Flyers, posters, and more.

Lower portions of the brand box may be overlapped by a person's head or other element to create depth. However, no portion of the COM Foundation logo itself may be obstructed.

The COM Foundation Brand Box carries over the principles of the standard brand box as a design approach to create visual structure for COM's Foundation logo usage in communications drawing distinction, focus and clarity for immediate brand recognition.

The COM Foundation Brand Box is reserved solely for the stacked COM Foundation logo and should be used in Institutional-based advertising only (no campus event-based advertising). The Foundation Brand Box should display a color from the approved color palette that visually enhances and supports the overall design. The COM Foundation logo should maintain sufficient contrast to the selected box color.

The COM Foundation Brand Box **must always appear anchored** to either the top (left or right), or in limited circumstances either the bottom (left or right), or center (top or bottom) in a design. When used in left or right positioning, the brand box should never be placed flush into a corner, but rather indented so it appears as a tab-like, banner element. Please see examples.

Only the COM stacked logo or a COM stacked Foundation logo may be used with a brand box.

# Logo: Usage in College Materials

## Self-Service Internal-Use Collateral Materials

- Internal-use collateral materials are solely meant for use within the College (e.g. “Taco Tuesday”). This includes, but is not limited to, program/recruiting events, announcements, marketing materials, etc.
- Internal-use collateral materials often do not require a logo. If a logo is desired, a marketing request must be submitted to the Marketing and Public Affairs Department to have the collateral piece designed.
- **Writing out “College of the Mainland” on any collateral material is not permitted. If branding is required, then a ticket for the collateral piece must be submitted to Marketing and Public Affairs.**

## External-Use Collateral Materials

- External-use collateral materials are designed to be seen by, and distributed within, the community. This includes, but is not limited to, program/recruiting events, announcements, marketing materials, etc.
- All external facing collateral materials must be created by the Marketing and Public Affairs Department.
- Please remember standard turnaround times for marketing requests begin at 10 working business days and increase depending on the complexity of the request.
- As subject matter experts, requestors should provide initial content for all materials.
- The term “external use” includes, but is not limited to, print materials such as fliers, postcards, promotional items, signs, etc.

### Self Service Collateral Materials

- College employees may create collateral advertisement materials for internal purposes as long as the piece does not include the college logo or the college name.
- If the collateral piece requires a College logo, it must be submitted to the Marketing and Public Affairs Department to have the logo added and to receive approval. The Purchasing Department will require an approval from Marketing for any materials including the COM logo.
- Writing out “College of the Mainland” on any piece of collateral material is also not permitted. If branding is required, then the collateral piece must be submitted to Marketing and Public Affairs for approval.

### Modifications to Approved Collateral

- All modifications to collateral materials designed by the Marketing and Public Affairs Department will need to be submitted for brand approval.

### Working With External Vendors

- Please work with established COM vendors. Established workflows have been created with vendors to ensure COM Marketing and Public Affairs projects operate efficiently.

# Logo: Incorrect Usage



Do not distort any portion of the logo



Do not substitute unapproved colors



Do not recreate the logo or alter the fonts



Do not add unapproved words or titles near the logo



Do not rotate



Do not use retired logo versions



Do not blend the "COM" logo with a play on words



Do not crop the logo



Do not add a drop shadow or other effects

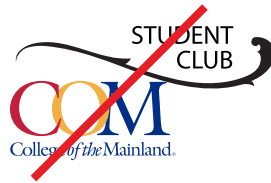

Do not blend with other logos or text elements



Do not use "COM" as a standalone element without Marketing approval



Do not use an extra registration mark after the large "COM"

Correct and consistent use of the College of the Mainland brand is an essential part of building brand integrity.

Do not alter or redraw the logo in any way. Illustrations on the left depict incorrect usages of the COM logo. Regardless of application, the logo must maintain its integrity.

Always use current, approved electronic artwork for the College of the Mainland brand.

Every element, including lettering, sizing, placement and color have been carefully designed and positioned using specific proportions.

With previous logos having been retired it is very important to use current artwork as specified in these guidelines.

**Note: Incorrect usage examples shown on the left also apply to all official COM logos including the mascot logo and the COM Foundation logos.**

The COM logo cannot be used for personal reasons or by external parties unless those individuals are under contract providing a service to the College that warrants use of the logo.



# Logo: College Departments

## Community-Facing Grandfathered Seals and Logos

### Community-Facing Department Seals



Nursing



Fire Technology  
(Fire Academy)



Law Enforcement  
(Police Academy)



Emergency Medical  
Services

### Community-Facing Department Logos



We are College of the Mainland. We are all part of one educational force with three shared goals united by a core visual brand presence across our touchpoints.

While each of our college departments are unique, we communicate the COM brand image as one entity simply displaying only the COM logo. This clear and unified brand approach for departments applies to all promotional related items such as pens, lanyards, tablecloths, t-shirts, tumblers, bags and more.

All college departments represent the college with a single official COM logo. However, a limited set of six college departments determined as core community-facing entities possess seals and logos that have obtained grandfathered level status allowing for their continued use. These six logos and seals must appear in conjunction with the official COM logo in all print publications, apparel, certificates, digital distributions or other uses.

All departments have the ability to personalize their unique areas with advertising and recruitment efforts through the use of business cards, custom designed retractables, fact sheets, recruitment cards, fliers, brochures, posters and other collateral.

Note: All COM logo guidelines presented in this document (including the use of adequate clear space and incorrect usage examples) also apply to all college department logos, the mascot logo and any other official logos. Each of the grandfathered college department logos shown on this page may be used in full color, white or black.

Have questions? Contact the marketing office or submit a request for assistance with your next event or advertising project.

The college name, "College of the Mainland", it's acronym "COM", and its respective logos all represent the brand of the college. Marketing manages the use and approval of all brand materials. Departments interested in using the college name or college logo displayed on any external public-facing materials (i.e., fliers, postcards, signage, apparel, or other communications) must receive prior approval from the Marketing and Public Affairs Office. Requests for approval should be submitted to:

[brandapproval@com.edu](mailto:brandapproval@com.edu)

# Mascot Logo: Club Sports – Fighting Ducks

All forms of the duck head mascot logo are trademark of College of the Mainland and may only be used with official college events, sponsorships, partnerships, official branded merchandise and initiatives determined by COM's Office of Marketing and Public Affairs. Unauthorized use is forbidden.

All requests to use the duck head separately from the curved COM design element must receive brand approval from the Office of Marketing and Public Affairs.

Official mascot logo with blue head and red lettering



The COM duck head mascot logo is one element consisting of the duck head and curved design text element as seen on the left.

Official mascot logo in black, gray and white



Official mascot logo colors follow COM's core colors:

"COM Red" PANTONE 200 C	"COM Yellow" PANTONE 143 C	"COM Blue" PANTONE 287 C
CMYK: 16, 100, 86, 7	CMYK: 2, 32, 91, 0	CMYK: 100, 87, 20, 11
RGB: 194, 4, 48	RGB: 246, 180, 54	RGB: 0, 47, 135
HEX: C20430	HEX: F6B436	HEX: 002F87

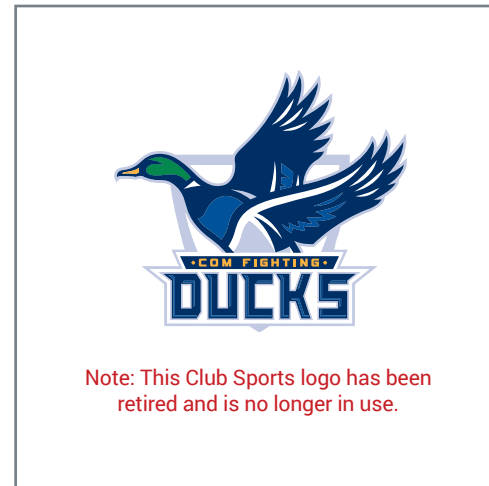

**Note: This Club Sports logo has been retired and is no longer in use.**

COM's Club Sports and Recreation mascot duck head logo embodies the school's spirit as it represents the mascot tagline "Fighting Ducks."

It illustrates a fighting spirit evoking a strong sense of determination, perseverance and confidence. This iconic element expresses the notion of what it means to be part of the COM student body (a Fighting Duck) instilling an inner drive to endure and succeed.

The duck head logo design proudly holds its own amongst other colleges across the U.S. elevating COM as a reputable force in higher education. The logo is designed in such a way that it is recognizable by its unique look versus a specific color allowing the COM sports brand flexibility in its promotion.

The core mascot logo is defined as the blue head, red outline and yellow bill. It is displayed in conjunction with the curved "COM" design element shown on the left. These elements must exist as one element, unseparated and remain proportionate.

Additional variations are defined on the next page.

# Mascot Logo: Club Sports – Fighting Ducks

One-color white logo



Hollow white

(White areas solid color)

One-color blue logo:  
PMS 280



Hollow blue

(White areas see-through)

One-color black logo



Hollow black

(White areas see-through)

One-color red logo



Hollow red

(White areas see-through)

## Additional variations:

Two-color logo: blue and yellow



Two-color logo: red and yellow



Pink logo with yellow bill



The mascot logo duck head is available in one color and two-color variations combined with the official “COM” element for use on apparel, promo and other items as needed in colors shown here.

As professional sports teams offer variations of their team name and brand design to draw a wider fan base and appeal to different interests, COM’s mascot logo duck head is available in several colors in combination with the curved “COM” text design element or the words “Fighting Ducks”. Important: “Fighting Ducks” can never be preceded by the word “the.”

Marketing requires a proof and approval of all mascot logos before they are printed, used and distributed.

All usage of official College of the Mainland logos, including the duck mascot logo, requires approval from the Marketing department before printing, publication, or other usage. This includes t-shirts and promotional items. Unapproved items may be removed from circulation.

# Mascot Logo: Club Sports – Fighting Ducks Clear Space

Correct spacing examples:

Official COM Mascot Logo



Clear space on all sides

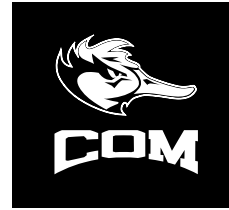

When positioning the mascot logo within a contained shape, and the intention is to display the full mascot logo uncropped, it is important to maintain balanced clear space around all sides.

Examples on the left illustrate correct and incorrect positioning.

While minimum clear space is required around the logo, larger amounts of clear space around the logo increase the respect of the brand. As the logo's size increases so should the proportion of clear space.

Clear space creates focus, integrity and richness allowing the logo to breath visually.

Incorrect clear space examples:



# Mascot Logo: Incorrect Usage



Do not distort any portion of the logo



Do not substitute unapproved colors



Do not change COM lettering appearance



Do not add text or other elements around the mascot logo



Do not rotate



Do not use retired logos



Do not separate the duck head from the curved COM lettering without Marketing approval. (See notes on the right)



Do not crop the mascot logo without Marketing approval



Do not add a drop shadow or other effects



Do not add words, names, or other logos without Marketing approval



Do not change proportions of the logo



College of the Mainland

Do not replace letters with college's full name

Correct and consistent use of the College of the Mainland brand is an essential part of building brand integrity.

Do not alter or redraw the mascot logo in any way. Illustrations on the left depict incorrect usages of the COM mascot logo. All guidelines apply to solid and hollow versions of the mascot logo. Regardless of application, the logo must maintain its original proportions and brand integrity.

Always use current, approved electronic artwork for the College of the Mainland brand.

Every element, including lettering, sizing, placement and color have been carefully designed and positioned using specific proportions.

Aside from pennants, the duck head may only be used in isolation if the back of the head is cropped off (i.e., a large head used across a magazine spread, a window application or wall graphic, or similar use).

With the previous logo having been retired it is very important to use current artwork as specified in these guidelines.

**Incorrect usage guidelines presented here apply to all COM logos and other official logos.**

# Mascot Logo Support Element: Fighting Ducks

All instances of the words “Fighting Ducks” on promotional material should use the varsity style graphic element shown below. Long sleeve usage should appear rotated 90° on the left side.

“Fighting Ducks” word mark varsity style: PMS 280.

# FIGHTING DUCKS

~~The Fighting Ducks~~

Note: the tagline “Fighting Ducks” should **never be preceded by the word “The”** when written or spoken.

The term “Fighting Ducks” is the official mascot identity for College of the Mainland.

The mascot identity “Fighting Ducks” should never be preceded by the word “The” when written. “**The** Fighting Ducks” word mark is a trademark owned by another entity. Our apparel and other material can only display the words “Fighting Ducks.”

When the mascot is mentioned in written or spoken material, references must be constructed as “... the **COM** Fighting Ducks...”

Note: Student Life is the only college department approved to use their department name in combination with the mascot logo.

**Fighting Ducks Mascot logo usage:** The Duck head logo may be used for internal Student Life events, sports, and student and spirit engagement.

The mascot logo may be used for Student Life swag and promo items where imprint size allows. An official COM logo is not needed in addition to duck logo on shirts, hats, etc.

Marketing oversees brand approval for all branded items for sale in the COM bookstore including those bearing COM logos and Fighting Ducks mascot logos.

## Student Life Department only

Official “Fighting Ducks” Student Life logo: PMS 280



Student Life “Fighting Ducks” long-sleeve tee



Right sleeve stacked COM logo in blue 3.5 in. wide

Left sleeve “Fighting Ducks” written trademark in blue 14 in. long

Front left chest, official “Fighting Ducks” Student Life logo 2.75 in. wide

Back center neck, official “Fighting Ducks” Student Life logo 2.0 in. wide

# Other College Logos: Horizons Magazine

COM Horizons masthead logo

# Horizons

The college's official magazine is titled Horizons.

The Horizons masthead logo is used to aid and promote public identification and recognition.

Bleed: 0.125 inches for all sides.

All artwork 300 dpi.



# Other College Logos: Texas Stars

The Texas Stars logo.



The Texas Stars logo with tagline.



The name Texas Stars represents the gracious and generous donors to COM's Foundation.

Texas Stars embodies a rich, luxury branding presence with a Texas flair comprised of 8 donation levels each named along a Texas-theme.

The tagline for Texas Stars is "Because of you, the stars shine big and bright." that speaks for the students it helps while aligning with the popular Texas song.

Texas Stars material should appear with a Texas feel such as browned paper, leather textures, and other rustic approaches. To further align materials with a Texas-look and night sky, the core brand colors were each intentionally dimmed (like a night sky) to align the brand with richer tones.

The Texas Stars logo, font and tagline written in Rockwell font should not be altered in any way and should be used with adequate clear space to preserve its integrity.

The Texas Stars logo that includes swirls and text may be used with or without the tagline.

The Texas Stars Donor Wall – Conference Center

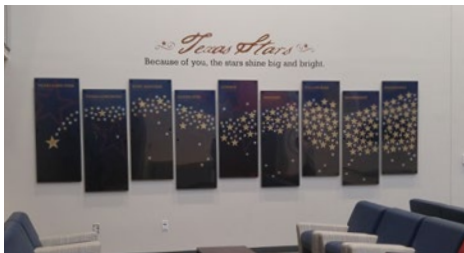

A Texas Stars Invitation example.



## Primary color palette

(dimmed COM palette for Texas Stars to create a richer, sophisticated look)



C: 56%  
M: 75%  
Y: 44%  
K: 27%

HEX: 674559

C: 25%  
M: 47%  
Y: 81%  
K: 5%

HEX: BA874A

C: 82%  
M: 71%  
Y: 41%  
K: 28%

HEX: 3A4660

## Additional secondary colors to support the Texas Stars theme

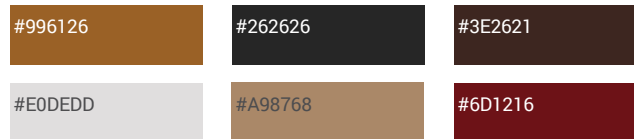



# Advertising Types:

- Institution-based
- Event-based

# Institution-based vs. Event-based Advertising

There are two main advertising categories for the college: Institution-based materials are official visual communications regarding recruitment, enrollment, registration, degrees, certificates, programs, donors and other similar collateral representing the college to the community. Event-based materials are geared specifically towards current students for events taking place on the college's main campus.

Institution-based advertisements take brand focus to its highest level. Therefore, institution-based advertising should only be produced by the Marketing and Public Affairs staff or their designates.

Event-based advertisements are for official on-campus activities advertised on some or all of the following: TVs, kiosks, website, social media, posters, fliers and postcards. With a goal of engaging students, event materials maintain design freedom allowing alignment with specific interests, culture and diversity while promoting a fabric of visual richness across campaigns. Considerations must always be taken into account how the brand will be received cohesively while generating event material.

The COM logo guidelines remain applicable in all material where the logo appears.

## Institution-based advertising examples:

- |                             |                       |
|-----------------------------|-----------------------|
| Campus signage              | Horizons magazine     |
| Vehicle signage             | External magazine ads |
| Billboards                  | Newspaper ads         |
| Digital marketing campaigns | Brochures             |
| Email signature             | Invitations           |
| Letterhead                  | COM Clothing          |
| Business cards              | COM Website           |
| Envelopes                   |                       |
| Promotional items           |                       |

## Event-based advertising examples:

- Digital displays (campus TVs)
- Kiosks
- Social media (extension of event)
- Fliers
- Posters
- Event postcards

# Institution-based Recruitment Materials: Non-Discrimination Statement

Recruiting materials are part of the college's Institution-based communications. All recruiting materials require the addition of the college's Non-Discrimination statement. This includes flyers, posters, etc.

There are 2 versions of the Non-Discrimination statement: A long, complete version and a short version when spacing is limited.

## Long English Version:

"The College District prohibits discrimination, including harassment, against any individual(s) on the basis of race, color, religion, national origin, age, veteran status, disability, sex, sexual orientation, gender, to include gender identity and gender expression, or any other basis prohibited by law. Retaliation against anyone involved in the complaint process is a violation of College District policy."

## Short English Version:

"COM does not discriminate based on race, color, religion, national origin, age, veteran status, disability, sex, sexual orientation, gender identity and gender expression, or any other basis prohibited by law."

## Long Spanish Version:

"El Distrito Universitario prohíbe la discriminación, incluyendo acoso, contra cualquier persona debido a su raza, color, religión, origen nacional, edad, condición de veterano, discapacidad, sexo, orientación sexual, género, el cual incluye identidad de género y expresión de género, o cualquier otra razón prohibida por ley. Las represalias contra cualquier persona implicada en el proceso de queja es una violación de la política del Distrito Universitario."

## Short Spanish Version:

"COM no discrimina debido a raza, color, religión, origen nacional, edad, condición de veterano, discapacidad, sexo, orientación sexual, identidad de género y expresión de género, o cualquier otra razón prohibida por ley."

The Non-Discrimination statement is required to be included in all newly developed college recruiting material beginning October 1, 2024.

The Non-Discrimination statement will visually be included in the form of a notice. From a hierarchical perspective, this is much like a photography credit or byline. The statement will use the font Roboto Regular, 7pt type, 9pt leading with a light gray color of CMYK: 0, 0, 0, 55 or hex color of #8b8c8f (if used over a white background).

Have questions about the addition of the Non-Discrimination statement in your marketing materials? Email: [brandapproval@com.edu](mailto:brandapproval@com.edu)

# Fonts: Institution-based vs. Event-based Comparison

Below are examples illustrating font and image design in Institution-based branding vs. Event-based branding.

## Institutional-based branding

- Often uses the Brand Box
- Fonts are primarily (if not all) Roboto
- Structured aesthetic using clear photography



## COM on-campus event-based branding

- No Brand Box usage, but logo is used
- Open to use other fonts to fit the event culture or “feel”
- Imagery style fluctuates



This sample set of Institution-based designs illustrate the correct use of fonts as it relates to the brand guidelines.

Institution-based materials that promote the brand directly will have an open, clean and conservative design aesthetic with ample clear space around all instances of the COM branding and typography used within the layout.

Main titles should maintain hierarchy and find balance within the overall design.

Event-based designs are more flexible on font use, but should remain professional, display effective communication for target audiences, maintain hierarchy principles and align with the subject matter. Clip art is not permissible in any design under any circumstances.

The marketing office designs and approves all institution and event-based materials bearing the COM brand and identity.

These materials must be professionally printed and should not have copies made on an office printer. This helps the college maintain a standard of professional, cohesive brand quality.

# Fonts: Institution-based Materials

## Primary font options for Institution-based titles

Roboto Bold Condensed – Use as ALL CAPS if used as a title

**ROBOTO**

Roboto Bold

**Roboto**

Roboto Light

Roboto

## Primary font for Institution-based short copy

Roboto Regular

Roboto

In most cases, Roboto title font usage should have tracking set to -20.

## Other fonts within the Roboto font family

Other Roboto font variations are acceptable, but consideration should be given by asking questions such as: Is the font choice legible at the final scale being used? Does the font style selected add to the integrity and visual balance of the piece? Does font usage maintain a bold, clear focus for the piece?

**Roboto Condensed** should primarily be used for short amounts of content only.

**Roboto Thin** variations should primarily be used for unique title or subtitle treatments where it can be used at larger sizes to maintain legibility.

**Italics** of any Roboto variation should be used minimally to accent only one or two words if needed. Never use as a full sentence.

**Roboto Black** is typically not used due to its smaller counterforms which affect legibility at smaller sizes. It also has a bulkier appearance conflicting with the overall intended use of Roboto for a sense of fresh and agile (whereas Black is leaning along lines of being clunky). Use should be limited, but if may be effective as single words in custom title treatments.

College of the Mainland's font use strategy embarks on presenting bold, clear visual messaging on all communication pieces.

To maintain a consistent appearance and modern brand identity, the official font for Institution-based advertising content is Roboto in both title treatments and short-body copy.

Roboto portrays a fresh, innovative, modern brand appeal with a clean structured letter form. It's overall thin to bold thicknesses evoke a sense of agility avoiding interpretations of bulky or clunky.

In main title treatments, Roboto should be used in either Bold Condensed (all caps), Bold or Light style. Short body content should use Roboto Regular. **All Roboto title font usage should have tracking set to -20** with kerning adjusted as needed.

Clear space is critical with all use of typography to create an open, visual flow of communication. With the exception of dynamic title treatments, negative space (clear space) must always be included around all text in a design layout. Learn more on the next page.

# Fonts: Institution-based Materials

## Limited-use sublevel accentuating fonts

Fontjek

**Fontjek**

These fonts should only be used for simple text treatments (titles, subtitles, accentuating word, date, etc).

Masker Area

**MASKER AREA**

These fonts should never be used for body content.

Varsity Team

**VARSITY**

Yellowtail

**Yellowtail**

## Secondary font for long-body content

PT Serif Regular

**PT Serif**

## Body content

Always include a minimum of about 1/4in of clear space around all sides of body content (as shown below) to maintain integrity in the piece.

When body content is laid out whether it be inside of a box shape – like this light blue box, or next to other shapes in a document, or near the edge of a document – a thick area of clear space is required around it (from the text's edge to the edge of the box). It should appear balanced on all sides for a uniform appearance.

Required clear space

**Incorrect.** This example illustrates incorrect clear space around text.

This is an example illustrating incorrect clear space between the outer block of text and the edge of the box. This limited amount of clear space around body content creates a cluttered and low quality design appearance. Adequate clear space is always required.

Additional Title fonts:

Three sublevel fonts are also available, limited to minimal use, for portions of a title or title phrase content. These are Masker Area, Varsity Team and Yellowtail.

Body Text:

PT Serif is used as a secondary body content font for longer documents and publications such as the Horizons magazine publications and some college handbooks.

Body content should always include a minimum of 1/4 inches of clear space around all sides of body content (see examples on the left) to maintain visual integrity in the piece.

As mentioned before, clear space is critical with all use of typography to create an open, visual flow of communication. With the exception of dynamic title treatments, negative space (clear space) must always be included around all text in a design layout.

# Logo Usage: Advertising Placement on Materials

If using a stacked COM logo

Flyers and posters

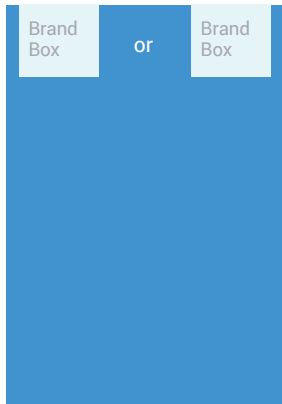

Retractables

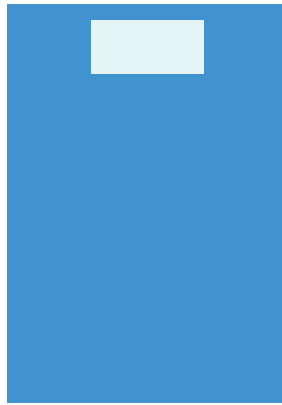

Formal Letterhead

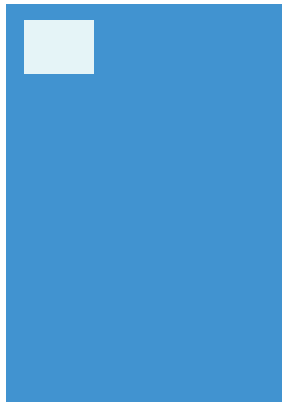

Newspaper and print ads

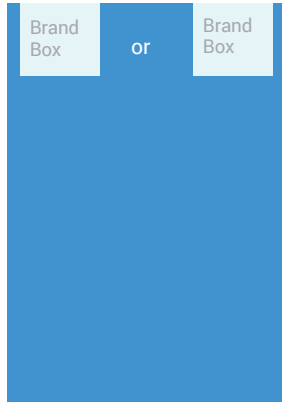

If using a horizontal COM logo

Flyers, posters, magazines,  
newspaper (top *or* bottom)



The COM logo has placement requirements across different advertising collateral.

Stacked logos should primarily be used with the logo Brand Box for Institutional purposes. Please refer to logo Brand Box guidelines earlier in this document.

Horizontal logos are limited to either top or bottom placement. These can be positioned left, right or center-aligned.

Usage of the COM logo in advertising and publications follows the same guidelines for color, style, sizing and hierarchy. Logo size will be determined by the logo's position on the page, other content and elements.

Regardless of use, the COM logo brand guidelines remain applicable in all materials where the logo appears.

Digital and print publication formats not listed here will adapt the logo as needed for best results determined by the Marketing department.

All usage of the College of the Mainland logo, in any material, requires approval from the Marketing department before printing, publication, or other usage. This includes T-Shirts and all promotional items. Unapproved items may be removed from circulation.

Please contact the Marketing department for assistance with your project.

# Logo Usage: Event-based Advertising

## When to use the COM Logo:

### **On-campus digital displays (TV monitors):**

COM logo not used.

### **On and off campus kiosks:**

COM logo not used.

### **Flyers:**

COM logo required in image.

### **Posters:**

COM logo required in image.

### **Mailed pieces (Postcards, invitations, etc):**

COM logo required.

### **External advertising (Billboards, magazines, etc):**

COM logo required in image.

### **COM social media posts:**

COM logo should not be included in advertising image.

### **Note:**

All mailed college material and campus event material open to the public must include the college's full address following the information below:

1200 N. Amburn Road  
Texas City, Texas 77591

Each campus event will have its own look and feel created as mini-campaigns. The look and feel will be maintained as it is reconfigured into different size formats.

There are no absolute color limitations of event-based designs, but it should be in good taste and reflect the event appropriately.

Colors of the designed piece should not visually conflict with the tri-color COM logo's colors. Alternative COM logos presented in these guidelines may be used as needed.

Visuals should represent the college and subject matter in a positive, professional and engaging light.

Given the variation of where event-based advertising may appear, the required and restricted use of the COM logo will vary. See the list on the left for details.

The COM logo may only be used with official college events, sponsorships, partnerships and initiatives. All materials bearing the college name, college acronym, or any official college logo require brand approval through the Marketing office before items are printed, produced or distributed. Please submit logo and brand requests to: [brandapproval@com.edu](mailto:brandapproval@com.edu)

Have an event coming up? Submit a request through the Marketing and Public Affairs Marketing Request System. Please allow a minimum of 3-weeks turn-around. Please note, more complex requests may have a longer turn-around time. Please contact the Marketing office to schedule a planning meeting for your event's advertising approach or if you have questions concerning your upcoming project.



# Logo Usage: Material Design and Distribution (On and Off Campus)

**This is OK.** Flyer/material does not bear any official COM logo, the college's acronym, or the college's written name:

Material that does not attempt to represent the college can be a DIY create your own flyer/other materials, with no print restrictions, and may be distributed on campus following guidelines and college policies.

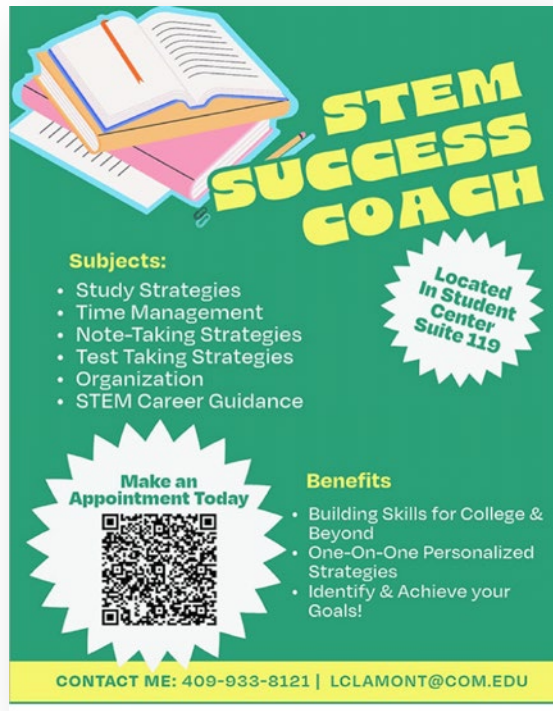

**Flyer/material bears COM branding:**

Material must be designed by the Marketing Department, professionally printed on specific paper, and distributed following guidelines and college policies.

Please note: Marketing does not advertise individual classes. Please set up a consultation for ad assistance.



The marketing office designs and approves all institution and event-based materials bearing the COM brand and identity.

Branded materials must be professionally printed and should not have copies made on an office printer. This helps the college maintain a standard of professional, cohesive brand quality.

**Designing your own flyer or other materials:** Materials that do not bear the college's name, the college acronym, or an official college logo, or do not attempt to reflect a representation of the college may be designed without the help of the Marketing Department, printed and distributed around campus at approved designated areas. These include bulletin boards and lounge area tables across the campus.

Please note, materials should never be taped to facility walls, elevators, doors or glass windows.

Materials distributed outside of these guidelines are subject to removal.

Have a question? Or logo and brand request? Please email the Marketing Department at: [brandapproval@com.edu](mailto:brandapproval@com.edu)

**Important:** Distributed DIY material should be college-specific and non-commercial. The College District prohibits discrimination, including harassment, against any individual on the basis of race, color, religion, national origin, age, veteran status, disability, sex, sexual orientation, gender (including gender identity and gender expression), or any other basis prohibited by law. Retaliation against anyone involved in the complaint process is a violation of College District policy.

# Institution-based: Brand Imagery

In general, all imagery used in any college materials, digital or print, should be bold, positive in nature and high quality utilizing photography with a clear resolution and focus.

Imagery used in institutional-based publications should use filters from the library of gradient maps seen here. Using these filters allow for a cohesiveness in college imagery communications and enhanced brand recognition.

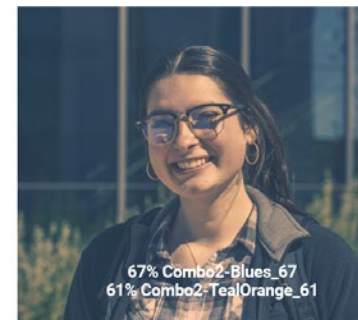
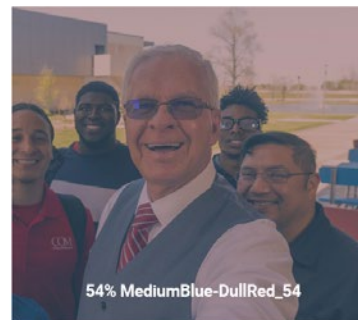
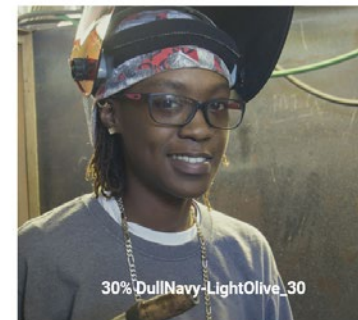
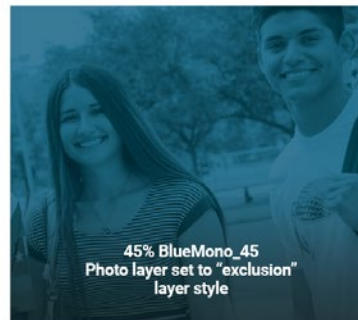
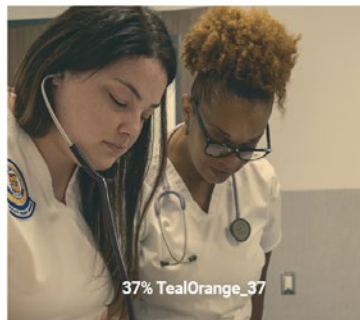
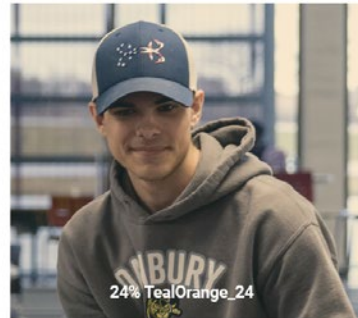
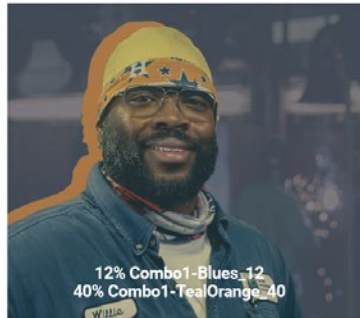

All imagery and visual communication (photos, logos, icons, artwork, text, promotions, etc.) used in official institution or event-based pieces should be positive in nature, high quality, high resolution and professional in nature. It should uphold and represent the intrinsic values of COM's brand as a respected institution.

Imagery used should be bold with a strong focal point acting as a supporting element to the message being presented to communicate and resonate with the intended audience effectively.

To convey a cohesive visual brand, all imagery used in institutional pieces should utilize **gradient map image filters shown on the left**. Values may be adjusted slightly depending on imagery needs. The marketing office manages all filter file resources.

**Please note:** Clip art is never permitted in any material including public-facing, institutional and event-based communications.

# Event-based Advertising: Typical Collateral

Kiosks: 1080 x 1920 pts.

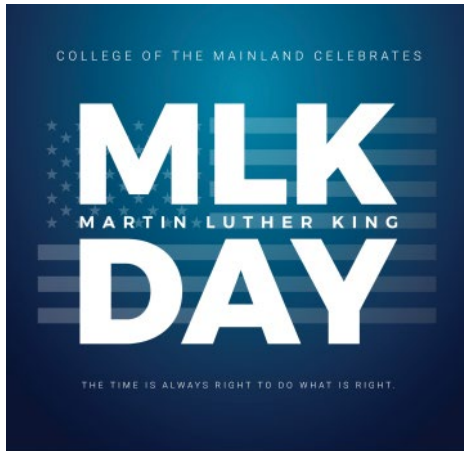

Digital displays: 1920 x 1080 pts.



Facebook: 1200 x 628 pts.



In some cases, 11x17 posters, 8.5x11 flyers, 5x8 half-page flyers, or 5x8 postcards may be needed.

Event-based communication is created across multiple digital and print formats as mini advertising campaigns. While the COM logo usage maintains its strict usage guidelines, other aspects of Event-based design pieces have greater design freedom and flexibility. Per event campaign, a design is created and then molded to adapt the various media channels.

Event-based designs should be professional in appearance that advocate student engagement and attendance. Hierarchy of information should be clear and concise with readability, comprehension and engagement possible within 12 seconds or less for digital usage.

Flyers and posters are designed with a 0.25 inch white border around all sides to avoid bleeds and additional printing costs.

Flyers, posters and postcards are designed at 150 dpi.

Digital displays, kiosks and social media are designed at 72 dpi.

The COM logo may only be used with official college events, sponsorships, partnerships and initiatives. All materials bearing the college name, college acronym, or any official college logo require brand approval through the Marketing office before items are printed, produced or distributed. Please submit logo and brand requests to: [brandapproval@com.edu](mailto:brandapproval@com.edu)

Have an event coming up? Submit a request through the Marketing and Public Affairs Marketing Request System. Please allow a minimum of 3-weeks turn-around. Please note, more complex requests may have a longer turn-around time.

# Event-based Advertising: Displaying Partnerships

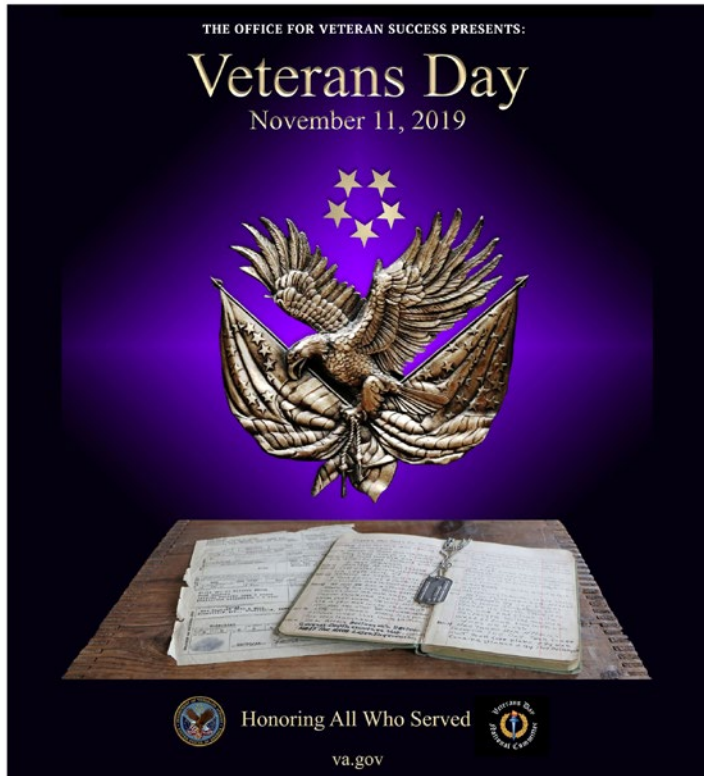

**Special Recognition:**  
98 year old Col/USMC/  
Retired Joe McPhail

**Guest speaker:**  
ACU of Texas and the SERVE  
(South East Resource Veterans' E-Net)

**November 12, 2019**  
**NOON - 1:00 p.m.**

College of the Mainland Conference Center



OPEN TO COM  
STUDENTS,  
FACULTY/STAFF  
AND COMMUNITY

Business logo and COM logo used together to show association or partnership in an event.

On occasion the COM logo may co-exist with external brands to show an association or partnership with an event.

In these scenarios each logo should be given adequate clear space and arranged hierarchically to show either equal sponsorship/partnership, a supporting role, or the leading role.

The COM logo may only be used with official college events, sponsorships, partnerships and initiatives.

Have an event coming up? Submit a request through the Marketing and Public Affairs Marketing Request System:

[com.edu/marketing](http://com.edu/marketing)

# Official Letterhead

Letterhead is available to download in print and digital formats from the **Marketing Resource Center** at <https://com0.sharepoint.com/sites/Marketing>

## Step 1:

In the top menu, click on the “Download Zone.”

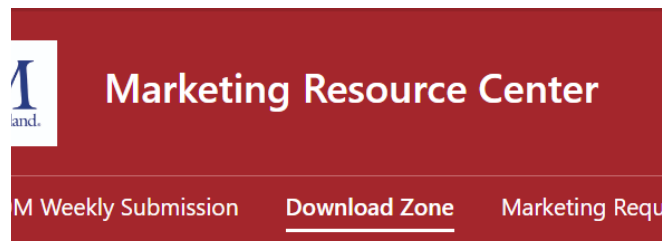

## Step 2:

Scroll down and locate the “Brand Toolbox” area and open the “Letterhead” folder.

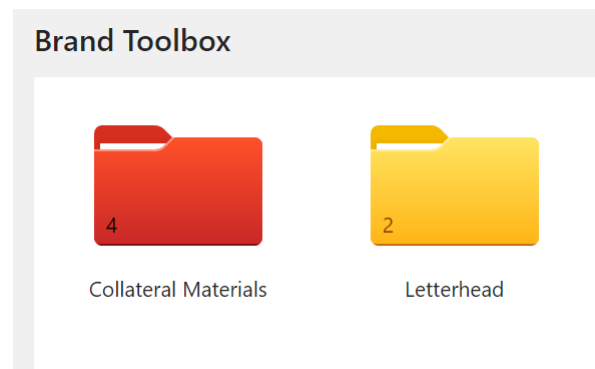

Within this folder are an official ready-to-use print version of the letterhead as well as a digital letterhead version for email use only.

**Print version:** Open the provided Word document and type in your content. Please do not change text box positioning, font, font color or sizes. Letterhead can only be printed on official letterhead paper which is available from the Marketing office. Place this paper in your printer and print the “print version” Word doc.

**Digital version:** This version should never be printed. Update the content in this document, save the file and then share via email as needed.

To build brand integrity, official brand communications in the form of letterhead, envelopes, thank you cards, PowerPoints and other collateral should maintain a consistent appearance with fonts, font size, font color and content placement.

The Marketing Resource Center offers ready-to-use resources for COM employees. The guidelines on the left offer guidance on how to use the letterhead resources.

These communication pieces are part of the Institution-based advertising as a formal facing element to the community.

# Official College Web Address

The official designation of the college website is simply “com.edu” without www.

Standalone examples of url depictions in advertising (where the url is not part of a sentence) should be written in Roboto Bold with -20 tracking.

**com.edu**  
**com.edu/events**

Instances where the website is not in standalone form can be written in Roboto Regular. Bold text is not required but the link text should utilize color to help draw focus.

Visit [com.edu/events](https://com.edu/events) to learn more.

The official designation of College of the Mainland’s website for advertising purposes is “**com.edu**”. It should be written consistently as a mark of stability and integrity for all advertising communications omitting any prefixes of “https://www.”.

All standalone uses of the COM website in advertising materials (standalone meaning the website url is not part of a sentence) should be written in Roboto Bold with -20 tracking.

The exception to omitting “www.” from the COM url are the college’s business cards where the website appears as www.com.edu. This is primarily to create better visual balance of content lengths on the card.

# Official College Physical Address: Display Standards

All digital and printed materials that include the college address should have consistent content and formatting using the font Roboto Regular.

## Stacked address (center-aligned) for envelope return address.

Color: #808285, Font size 8pt, Leading 10pt, 0 tracking



1200 N. Amburn Road  
Texas City, Texas 77591

## One line address (center-aligned)

Color: #808285, Font size 9pt, Leading 13pt, -20 tracking

1200 N. Amburn Road, Texas City, Texas 77591

## One line footer address with website and/or other information added (center-aligned):

1200 N. Amburn Road, Texas City, Texas 77591 • 409-938-1211 • com.edu

## Stacked footer address

### (left-aligned or right-aligned):

1200 N. Amburn Road  
Texas City, Texas 77591  
409-938-1211  
1-888-258-8859  
com.edu

## Two lines, address and web (center-aligned) for COM Letterhead address (footer text) and Thank You cards (back).

Color: #8a8c8e, Font size 9pt, Leading 13pt

1200 N. Amburn Road, Texas City, Texas 77591  
com.edu

Consistency of the college address is important to further exemplify stability and integrity.

The address should first state "1200" followed by "N." (with a period), Amburn and the word "Road" spelled out. Kerning should be adjusted between the "1" and "2" in "1200." "Texas City," should be followed by "Texas" spelled out with the zip code.

When used as a footer, place the order as address first, then phone number (the number separated using hyphens), then the COM website written as "com.edu" (omitting https://www), all center-aligned with two spaces around each separating bullet point.

With **envelope layout**, either a stacked COM logo or stacked Foundation logo is placed in the upper left corner with a 5/16 inch clear space along the top and left side, from the logo's edge to the edge of the envelope. \*The top guideline should align with the "M" in "COM's" top serifs.

These communication pieces are part of the Institution-based advertising as a formal facing element to the community.

# Official Email Signature: Display Standards

Create your email signature using Arial.  
Bold your name and the college's name.

ARIAL BOLD, 11PT TYPE \_\_\_\_\_

**First Last Name**

ARIAL REGULAR, 10 PT TYPE \_\_\_\_\_

Official position title

ARIAL BOLD, 11PT TYPE \_\_\_\_\_

**College of the Mainland**

ARIAL REGULAR, 10 PT TYPE \_\_\_\_\_

Name of your department

1200 N. Amburn Road

Texas City, Texas 77591

409-933-8039

[youremail@com.edu](mailto:youremail@com.edu)

Download and insert the official college logo to include in your email signature.

Complete how-to steps can be found in the network's Marketing folder.

All departments, with the exception of the COM Foundation (logo below), use the official COM logo in the email signature.



With email as a primary tool of communication, its appearance and signature is one of the first impressions of the college. Working together and using a consistent format for our email signatures portrays a sense of professionalism and integrity for College of the Mainland as a cohesive institution of excellence.

To insure consistency across various email clients, COM's email signatures use Arial Regular with your name and the college name in Arial Bold. Color the college name in red. All other text is Arial Regular in black with your phone number (using hyphens) and your COM email address. Add a blank return and insert the official COM logo from the network folder.

Employee names may include middle names, initials, credentials and honorifics as space permits. Specific office numbers and suites are not included with the address.

All college departments, with the exception of the COM Foundation, use the official COM logo in the email signature.

**Setup your email signature:**  
Complete how-to steps can be found in the network's Marketing folder.



# Official Business Cards

Business cards can be ordered through the Marketing Resource Center's Self Service section.

**Visit:** <https://com0.sharepoint.com/sites/Marketing>



## Step 1:

In the top menu, click on the "Download Zone."

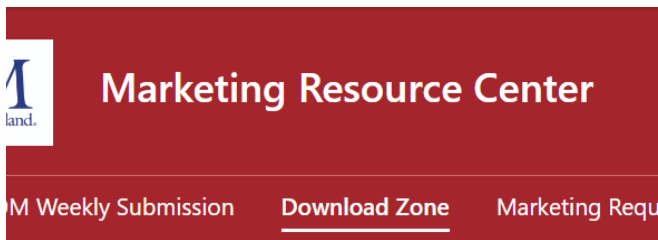

## Step 2:

Scroll down and locate "Order Official Stationery" area and click on the link "Slate Print Shop" to begin.

Please note: Only Administrative Assistants are able to place orders.

### Order Official Stationery

Official stationery may be ordered online through the [Slate Print Shop](#). At this time only administrative assistants are able to place orders.

Business cards are an integral part of the institutional-based advertising category shared amongst partners, media, businesses and the community.

COM's Marketing Resource Center provides a self-service model online to expedite ordering business cards, name tags and stationery.

Business cards will display one line in bold for the employee's name (one line only), a second line in all caps designating the employee's official position (one line only) and a third line in title case displaying the employee's department name (one line only). All fonts and font sizes must remain set to original specifications. The department name will **not include** the word "department."

Employee names may include middle names, initials, credentials and honorifics as space permits.

Associate and Bachelor degree credentials are not included on business cards.

Specific office numbers and suites are not included in the address.

# Official Name Tags

Name tags can be ordered through the Marketing Resource Center's Self Service section.

Visit: <https://com0.sharepoint.com/sites/Marketing>



Name tags are an integral part of the institutional-based advertising category shared amongst partners, media, businesses and the community.

COM's Marketing Resource Center provides a self-service model online to expedite ordering business cards, name tags and stationery.

Given their smaller size, name tags have a very small area to display names and employee information. As a result there are content limitations to ensure everyone, regardless of name length, has equal representation.

Employee names will be displayed in title case on up to two lines in bold (2nd line overflow appears above), a second line in all caps designating the employee's official position (one line only with a limit of 29-30 characters) and a third line in all caps displaying the employee's department name (one line only with a limit of 29-30 characters). All fonts and font sizes must remain set to original specifications. Due to limited line length and to maintain standardized clear space, some position titles may need to be shortened or abbreviated. The department name will not include the word "department." Employee names may include middle names and initials as space permits, but no credentials or honorifics may be used with the exception of "Dr." to be placed in front of an employee name where applicable.

Need a new business card, name tag or stationery?

Visit the [Marketing Resource Center](#) at the link provided on the left. From the "Home" tab shown in step 2, scroll down to explore the "Self Service" section of the site.

## Step 1:

In the top menu, click on the "Download Zone."

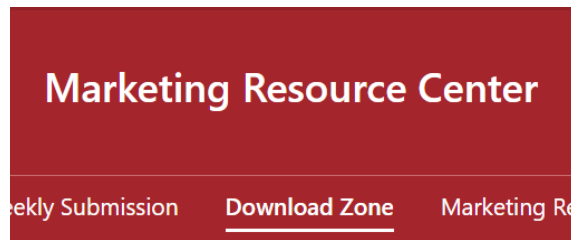

## Step 2:

Scroll down and locate "Order Official Stationery" area and click on the link "Slate Print Shop" to begin.

Please note: Only Administrative Assistants are able to place orders.

**Order Official Stationery**

Official stationery may be ordered online through the [Slate Print Shop](#). At this time only administrative assistants are able to place orders.

# Official PowerPoint Templates

COM PowerPoint Templates are available for download from the **Marketing Resource Center** at <https://com0.sharepoint.com/sites/Marketing>

## Step 1:

In the top menu, click on the “Download Zone.”

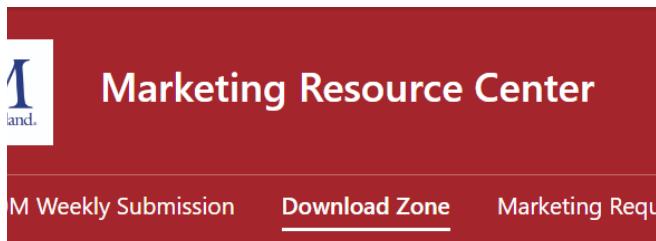

## Step 2:

Scroll down and locate the “Templates” area and open the “PowerPoint” folder.

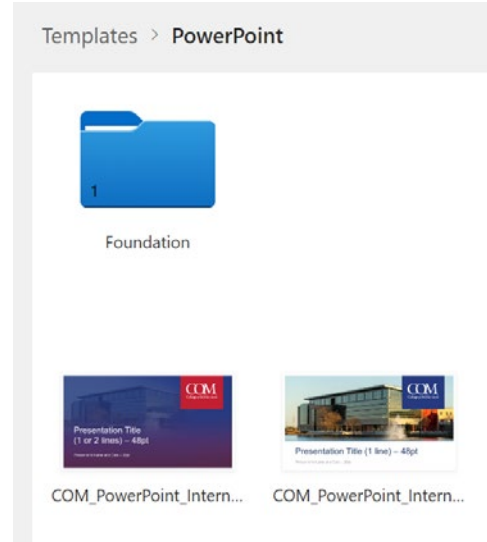

Within this folder are official ready-to-use PowerPoint templates.

To build brand integrity, official brand communications in the form of letterhead, envelopes, thank you cards, PowerPoints and other collateral should maintain a consistent appearance with fonts, font size, font color and content placement.

The Marketing Resource Center offers ready-to-use resources for COM employees. The guidelines on the left offer guidance on how to access the PowerPoint resources.

These communication pieces are part of the Institution-based advertising as a formal facing element to the community.

# Official Promotional Items

## Interested in COM branded merchandise?

Visit: <https://proformaprostores.com>

### Quick & easy!

The COM Proforma Pro Store is full of ready-to-order branded promotional items that have all been pre-approved by the Marketing team.

### Login, order and go!

COM's new online Proforma Pro Store offers a wide array of drinkware, pens, bags, event materials and more.

It's quick and easy. Just visit <https://proformaprostores.com> and order your own pre-approved College of the Mainland branded promo items.

Can't find what you need or have questions about the use of a COM logo? Email: [brandapproval@com.edu](mailto:brandapproval@com.edu)

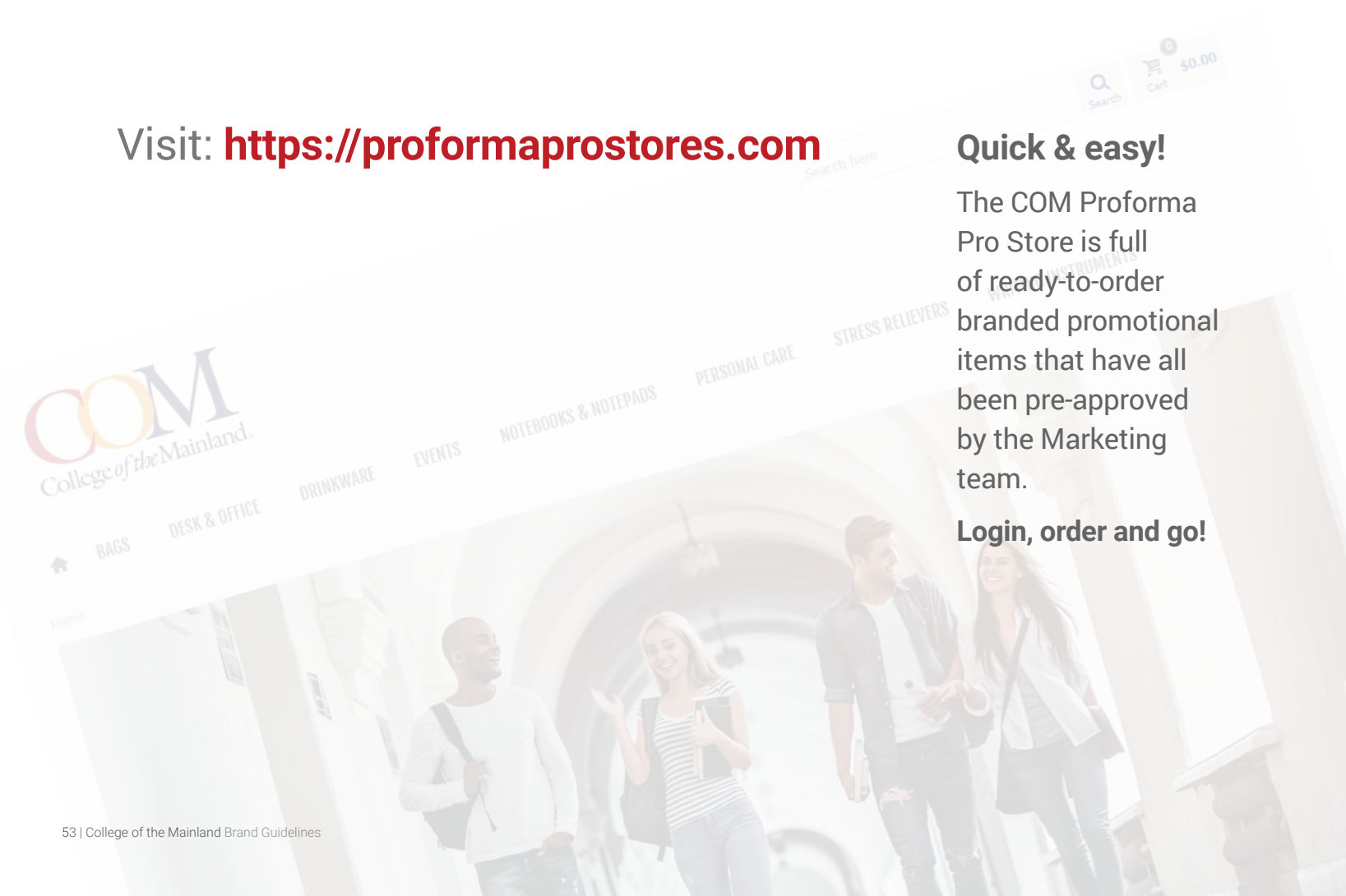

# Promotional: COM Product Colors

This page illustrates the master color palette for physical promotional items for use with variants of the COM logo. Please see the following page for specific details.

## Primary promotional color palette

"COM Red"	"COM Yellow"	"COM Blue"
<b>PANTONE: 200 C</b>  C: 16 M: 100 Y: 86 K: 7	<b>PANTONE: 143 C</b>  C: 2 M: 32 Y: 91 K: 0	<b>PANTONE: 287 C</b>  C: 100 M: 87 Y: 20 K: 11

## Secondary color promotional palette

<b>PANTONE: 3005 C</b>  C: 100 M: 46 Y: 2 K: 0	<b>PANTONE: 120 C</b>  C: 1 M: 12 Y: 72 K: 0	<b>GRAY-TONED CAMOUFLAGE</b>	<b>PANTONE: 3568 C</b>  C: 0 M: 21 Y: 4 K: 0
<b>PANTONE: 2995 C</b>  C: 73 M: 16 Y: 0 K: 0	<b>PANTONE: 600 C</b>  C: 7 M: 2 Y: 48 K: 0	<b>WHITE</b>	<b>PANTONE: 212 C</b>  C: 0 M: 83 Y: 5 K: 0
<b>PANTONE: 297 C</b>  C: 52 M: 4 Y: 3 K: 0		<b>BLACK</b>	<b>VARIOUS SHADES OF GRAY</b>
<b>PANTONE: 317 C</b>  C: 29 M: 0 Y: 11 K: 0			

Official COM logos (stacked and horizontal). Please refer to logo guidelines for colors and usage.



Note: In most apparel and promotional items, the COM stacked logo should be used.

To maintain brand integrity, College of the Mainland offers a standardized color palette for promotional items **bearing the official COM logo**.

This page illustrates the approved colors for physical promotional items which include the brand's primary color palette, select colors from the secondary palette, black, white, various shades of gray, light pink, hot pink and gray-toned camouflage.

Note: All products and items bearing the college name, college acronym, or any official college logo require brand approval through the Marketing office before items are printed, produced or distributed. Please submit requests to [brandapproval@com.edu](mailto:brandapproval@com.edu)

Please see the following page for logo color and background color combination usage.

# Promotional: COM Logo Color Combinations

Product colors and corresponding COM logo color use.

White COM logo over color



Black COM logo over color



“COM Blue” logo over color



Full color COM logo over white



Full color logo over light gray not to exceed 15% value of black.



5% value of black



10% value of black



MAXIMUM GRAY DARKNESS: 15% value of black

Please note: Gray-toned camouflage requires a white notched COM logo over a black box for legibility. All logos contained in box shapes must follow minimum clear space proportions as shown in example above. The logo should be centered and not encroach the edge of the box, but rather have balanced clear space around it.

Please note: Standard embroidery width (Polo shirt, left chest) for the COM stacked logo is 3in wide maintaining proportional height.

Due to printing restrictions most promotional items are printed with either a black or white logo. Sufficient contrast between the logo and item color must always be considered for legibility.

Background colors are shown with appropriate COM logo color combinations.

**Color exception:** In cases where Pantone colors are not possible, navy products may be substituted in place of the COM Blue when using the white COM logo.

The full color COM logo may only be used over a solid white background or light gray with the gray not exceeding a 15% value of black to maintain legibility.

# Promotional: Mascot Logo Product Colors

This page illustrates the master color palette for physical promotional items for use with variants of the COM mascot duck logo. Please see the following page for specific details.

## Primary promotional color palette

"COM Red"	"COM Yellow"	"COM Blue"
<b>PANTONE: 200 C</b> C: 16 M: 100 Y: 86 K: 7	<b>PANTONE: 143 C</b> C: 2 M: 32 Y: 91 K: 0	<b>PANTONE: 287 C</b> C: 100 M: 87 Y: 20 K: 11

## Secondary color promotional palette

<b>PANTONE: 3005 C</b> C: 100 M: 46 Y: 2 K: 0	<b>PANTONE: 120 C</b> C: 1 M: 12 Y: 72 K: 0	<b>GRAY-TONED CAMOUFLAGE</b>	<b>PANTONE: 3568 C</b> C: 0 M: 21 Y: 4 K: 0
<b>PANTONE: 2995 C</b> C: 73 M: 16 Y: 0 K: 0	<b>PANTONE: 600 C</b> C: 7 M: 2 Y: 48 K: 0	<b>WHITE</b>	<b>PANTONE: 212 C</b> C: 0 M: 83 Y: 5 K: 0
<b>PANTONE: 297 C</b> C: 52 M: 4 Y: 3 K: 0		<b>VARIOUS SHADES OF GRAY</b>	
<b>PANTONE: 317 C</b> C: 29 M: 0 Y: 11 K: 0		<b>BLACK</b>	



Official COM mascot logo. Please refer to mascot logo guidelines in this document for logo information.

To maintain brand integrity, College of the Mainland offers a standardized color palette for promotional items **bearing the official COM mascot logo**.

This page illustrates the approved colors for physical promotional items which include the brand's primary color palette, select colors from the secondary palette, black, white, various shades of gray, light pink, hot pink and gray-toned camouflage.

Note: All products and items bearing the college name, college acronym, or any official college logo require brand approval through the Marketing office before items are printed, produced or distributed. Please submit requests to [brandapproval@com.edu](mailto:brandapproval@com.edu)

Please see the following page for color combination usage.

# Promotional: Hollow One-Color Mascot Logo Color Combinations

Product colors and corresponding COM mascot logo color use.



The mascot logo comes in two main forms: hollow and solid. This page illustrates hollow color guidelines. Please see solid options on the next page.

Hollow white logo over color

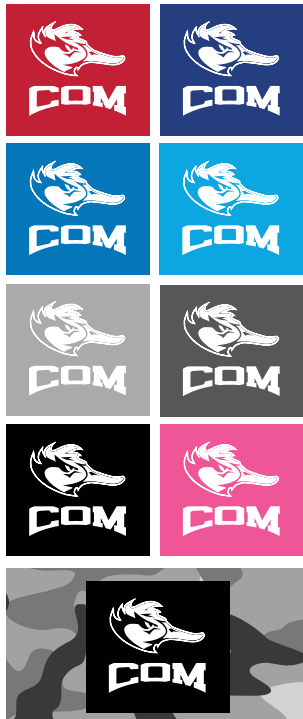

Hollow black logo over color



Hollow "COM Blue" logo over color



Please note: Gray-toned camouflage requires a hollow white mascot logo over a black box for legibility. All logos contained in box shapes must follow clear space proportions as shown above. The logo should not encroach the edge of the box, but rather have balanced space around it.



Hollow white logo over "COM Blue"

Hollow white logo over black



Due to printing restrictions most promotional items are printed with either a black or white logo. Sufficient contrast between the logo and item color must always be considered for legibility.

For example, promotional items that are dark in color like COM blue, COM red, or black should always use a white mascot logo.

Background colors are shown with appropriate COM mascot logo color combinations.

**Color exception:** In cases where Pantone colors are not possible, navy products may be substituted in place of the COM Blue when using the white COM logo.

**Please note:** The *white* hollow logo is purposefully designed in a different way compared to the other solid color hollow logos.

For example, the white logo allows the dark color of the product to act as the dark areas of the eye. Black and blue hollow logos cannot be changed to white and vice versa.

Hollow black logo over red



Hollow white logo over red

Hollow white logo over pink bag



Camouflage example courtesy of Vecteezy.com.



# Promotional: Solid Full-Color Mascot Color Combinations

Product colors and corresponding COM mascot logo use.

Solid full color logo over color

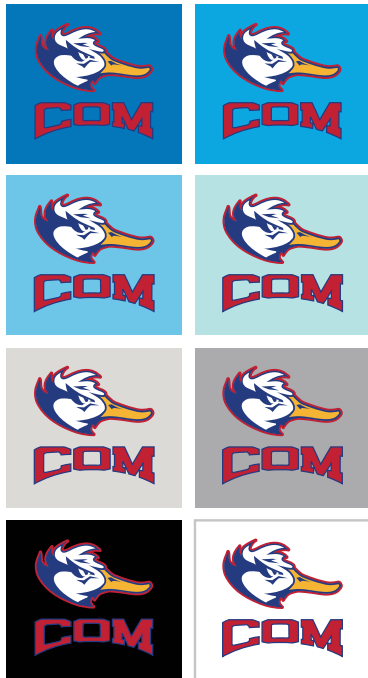

Solid pink logo over color



Solid pink logo over black shirt



Solid full color logo over black shirt

Full color mascot logos consist of the blue head duck with red COM lettering, and a pink head duck with pink lettering. These solid mascot logos have a limited set of promotional item colors that can be used to maintain contrast and legibility.

Background colors are shown with appropriate COM mascot logo color combinations.

Mascot logos used as large graphic elements on shirts, drawstring bags and other products must use large amounts of clear space around all sides of the logo. Logos may not be used without adequate clear space. Please reference logo proportions on the shirt examples and bag examples on the left. Marketing's brand approval process will provide final guidance on logo proportions.

Note: All products and items bearing the college name, college acronym, or any official college logo require brand approval through the Marketing office before items are printed, produced or distributed. Please submit brand requests to [brandapproval@com.edu](mailto:brandapproval@com.edu)

# Promotional: Meta-Major Logo Usage and Color Combinations

Product colors and corresponding Meta-Major logo color use.

Arts logo over color



Business logo over color



Health logo over color



Science logo over color

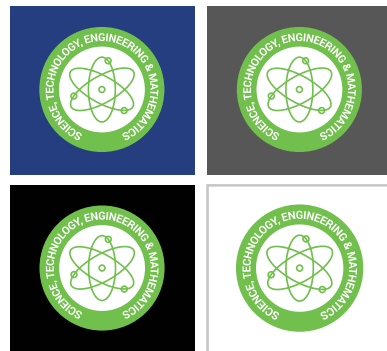

Meta-Major logos are only permitted for use on shirts. Collared shirts display them on the front chest accompanied by the stacked COM logo on the back neck.

T-shirts are opposite with the COM logo on the chest and a large Meta-Major logo on the back.



Front chest Meta-Major logo should be 2.75 in. wide.



Back neck COM logo should be 2.0 in. wide.



Background promotional item color

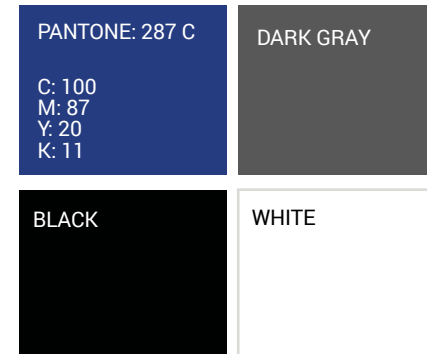

The Meta-Major logos represent high-level curriculum categories at COM. These logos have a limited background color option consisting only of COM Blue (or navy), dark gray, black or white.

Meta-Major logos are currently only permitted for use on shirts. Shirts must display the Meta-Major on the left chest in combination with the stacked COM logo on the back neck. The COM logo must be white or black.

Meta-Major logos consists of white and a dominant native color that must be maintained: Arts is light blue, Business is orange, Health is red, and Science is light green. Colors are derived from COM's secondary color palette. These logos should not be used in black or white, or changed to other colors.

Background colors are shown with appropriate COM Meta-Major logo color combinations.

All shirts bearing Meta-Major logos require brand approval through the Marketing office before items are printed, produced or distributed. Please send brand approval requests to [brandapproval@com.edu](mailto:brandapproval@com.edu)

# Indoor Retractable Banners

Indoor retractable banners are produced for you by the marketing staff.



36 in.

COM logo centered at the top

One or two word focal title in all caps that defines the main topic of what the retractable is about.

The Theatre department's retractable is 36 inches wide.

All other large retractables are 32.75 inches wide.

Retractable are created at 150dpi.



32.75 in.

85.7 in.

Bleed: 0.5 inches for Top, Left and Right. 6 inches for the bottom.

Official signage must follow logo brand guidelines in all applications.

Indoor retractable banners are designed to engage in hallway and expo locations.

Retractable signage must include the vertical COM logo placed at the top, and if representing a department, is followed by a short (one or two word) bold header element in all caps that identifies the department.

Retractable should contain one large focal image or a series of images to draw visual interest. Marketing suggests keeping content high level and simple. It's not good practice to include office contact info such as phone and email.

A retractable's purpose is to act as a large visual backdrop presenting the college name and high-level information attracting people to your table. Once at the table, conversations begin and smaller professional handheld items are given out containing next steps and contact info (i.e., recruitment cards, business cards, flyers, etc).

Need a retractable banner? Submit a request through the Marketing and Public Affairs Marketing Request System at: [com.edu/marketing](http://com.edu/marketing)

Please allow a minimum of 4-weeks for your request to be completed.

# **Signage & Design:** Facility and Campus Alignment

# Campus Signage & Design: All Facilities – Design, Finishes & Wayfinding

All campus and building signage (including interior, exterior, permanent or temporary) created by internal staff or external parties must be submitted as proofs to the Office of Marketing and Public Affairs for brand approval prior to printing, production, distribution and installation:

[brandapproval@com.edu](mailto:brandapproval@com.edu)

As stated on page 4 of these guidelines, the COM brand is more than just a logo. It is the impression and feeling encountered at any of the college's touchpoints. All facilities, whether main campus or external, are college touchpoints. External college facilities are an extension of the COM brand and must maintain the integrity of the brand name and its brand image as an institution of excellence.

As the managing department of the college's brand, the Marketing office requires its involvement and participation in all facility and campus design-related decisions, including exterior and interior signage, wayfinding, parking signage, perimeter and entrance signage, emergency signage, murals, facility interior design, paint colors, finishes, office name plates and all other visual communication aspects from the planning stages through implementation.

Brand approval is required prior to production and implementation for any type of logo use, signage, building lettering, facility exterior and interior design, or their respective modifications.



# Campus Signage Wayfinding: Main Campus — The Onion Philosophy

## Wayfinding Design System Hierarchy of Critical Signage:

- Exterior perimeter (roadway arteries): Perimeter Lead directional signage
  - Exterior perimeter (campus property): COM Logo (corner structures)
  - Exterior perimeter (campus property): Vehicular entrance points and building visibility
  - Interior perimeter: Parking directionals and parking lot identification
  - Interior perimeter: Donor building names and community-facing facilities (white channel lettering)
  - Interior perimeter: Building monument IDs (vehicular and pedestrian outer-facing)
  - Inner campus: Map monument IDs (pedestrian campus entry points)
  - Inner campus: Foot traffic directionals (pedestrian)
  - Building interiors: Navigational menus (floor directories and journey point signage)
  - Building interiors: Numeric journey blocks (with optional appended elements)
  - Building interiors: Room plaques

Dark blue is reserved as the background for the COM logo for maximum contrast and legibility. It is used on signage with the logo in white on exterior perimeter signage. All dark blue applications will also use a complimenting medium blue for panels containing the journey point information. For example, dark blue would appear on a Monticello corner sign, tops of perimeter leads and on vehicular entrance signs.

Medium blue represents **near proximity journey point destinations** exterior and interior. The upper portion of exterior Monument IDs are displayed on medium blue. Interior journey point signage uses the same medium blue (i.e., Signs like “Showers”, “Elevator”, etc).

**Distant journey points** (relatively) are represented with grays. Exterior walking traffic is displayed on peppercorn gray. And the bottom portion of Monument IDs are in peppercorn gray for other campus locations. Non-active floors (location-based viewing) are also gray, but utilize a darker shade.

Red is reserved for “areas of notice” (aside from parking lot B color coding). This includes map monument signage, emergency signage, red elevator walls, and the active floor on floor directory signage.

**The Onion Philosophy:** The college’s wayfinding design system will be designed like the skin of an onion, peeling back layers as you encounter the next level of hierarchy revealing new pertinent information.

The college’s name and logo will maintain hierarchical dominance from the highway. As the destination continues, new levels of signage and journey point guidance emerges leading with information of importance.

All college signage (exterior and interior) must maintain a clean, cohesive appearance for a consistent user experience campus-wide, that maintains legibility and wayfinding clarity.

All campus and building signage (including interior, exterior, permanent or temporary) created by internal staff or external parties must be submitted as proofs to the Office of Marketing and Public Affairs for brand approval prior to printing, production, distribution and installation:

[brandapproval@com.edu](mailto:brandapproval@com.edu)

# Campus Signage & Design: Partial Wayfinding System at a Glance

## EXTERIOR



All campus and building signage (including interior, exterior, permanent or temporary) created by internal staff or external parties must be submitted as proofs to the Office of Marketing and Public Affairs for brand approval prior to printing, production, distribution and installation:

[brandapproval@com.edu](mailto:brandapproval@com.edu)

## INTERIOR

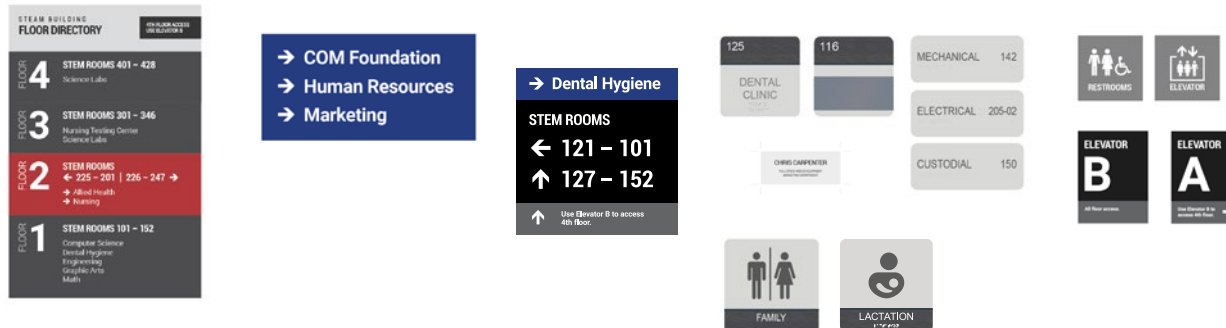

# Campus Signage & Design: Navigational Brand Arrows



Navigational arrows are a core element to all wayfinding. All wayfinding, interior and exterior, requiring the use of a navigational arrow will use this official brand arrow shape for cohesiveness and consistency across the design system. No other arrow designs or pointers are permitted. Arrows must maintain their integrity and may not be stretched, squished or distorted.

Arrows will appear in white over a dark, high contrast background color. In limited circumstances, the Marketing brand office may approve a dark arrow over a light background.

Brand arrows can be positioned vertical, downward, right, left and at 45°.



All campus and building signage (including interior, exterior, permanent or temporary) created by internal staff or external parties must be submitted as proofs to the Office of Marketing and Public Affairs for brand approval prior to printing, production, distribution and installation:

[brandapproval@com.edu](mailto:brandapproval@com.edu)



# Campus Signage & Design: Navigational Arrow Alignment

Navigational menu

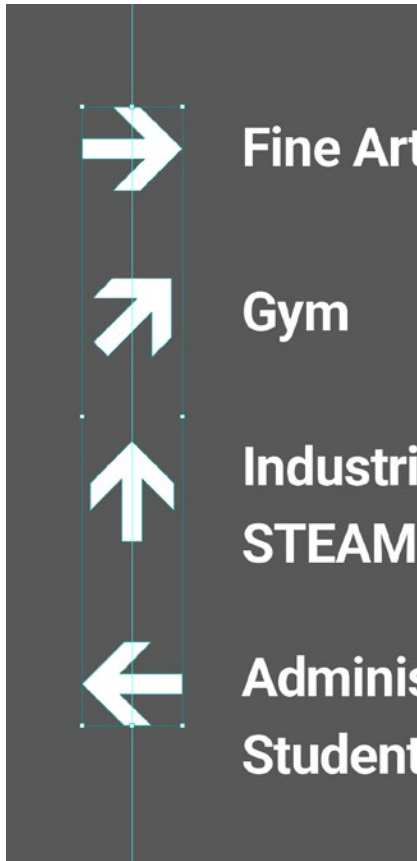

## Exterior & Interior Applications:

Arrows will always appear on the left of any content menu regardless of the direction the arrows are pointing for a clear navigational structure. \*There are limited exceptions noted on a later page.

When more than one arrow is used in a navigational menu like this example on the left, arrows should align on their center axis vertically.

All arrows used in the same sign or menu must be used at the same scale.



Distance between an arrow and content example

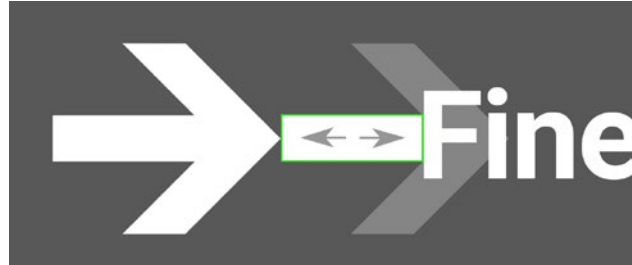

Depending on the application (exterior to interior), navigational arrows will be used at different scales. To maintain a proportional distance between a navigational arrow and content at any scale, **begin with a right-pointing arrow** at final scale as a guide. Make a copy of the right-pointing arrow and adjust so the horizontal stalk's width marks the distance between the right-pointing arrow's tip and left edge of the content (i.e., Fine) not including the winged-portion of the arrow shown grayed out above. This distance will establish the left-alignment edge for all menu content. Next rotate the arrow up, at a 45, or flipped if needed.

All campus and building signage (including interior, exterior, permanent or temporary) created by internal staff or external parties must be submitted as proofs to the Office of Marketing and Public Affairs for brand approval prior to printing, production, distribution and installation:

[brandapproval@com.edu](mailto:brandapproval@com.edu)

# Campus Signage & Design: Navigational Arrow Alignment

Example 1: Close-up of interior navigational menu

Left and right arrow capital letter alignment:



Up arrow center alignment



All standard navigational menus will display navigational arrows to the left of menu content.

Arrow size will be based on the type of sign. Example 1 shows a Journey Point sign (blue with white letters). A right or left arrow will align top and bottom to the capital "E".

An upfacing arrow remains the same size, rotated with its point and base extending above and below the capline and baseline as seen above. The scale of this arrow will be used for other menu items in the same sign.

Example 2: Exterior Monument ID

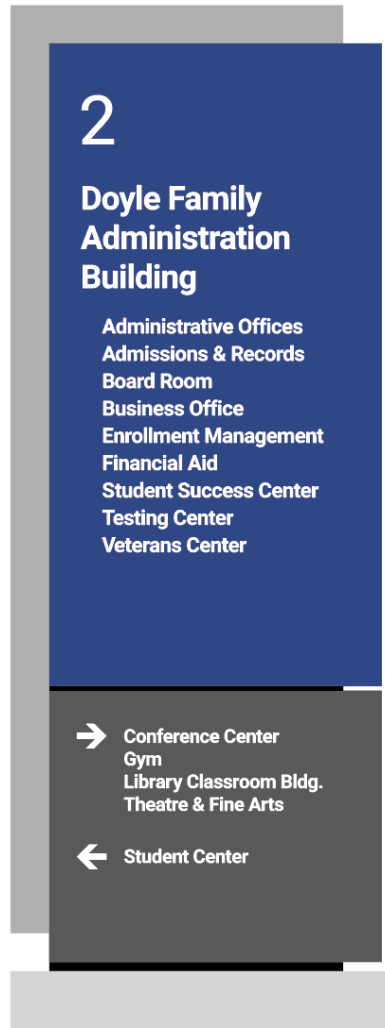

In example 2, a navigational menu appears at the bottom of this Monument ID sign. Users digest information in the vicinity of the sign, but at a further distance. As a result, arrows are intentionally scaled slightly larger in this lower navigational section. Arrows are aligned on their center axis and all arrows in this area are the same size.

All campus and building signage (including interior, exterior, permanent or temporary) created by internal staff or external parties must be submitted as proofs to the Office of Marketing and Public Affairs for brand approval prior to printing, production, distribution and installation:

[brandapproval@com.edu](mailto:brandapproval@com.edu)

# Campus Signage & Design: Navigational Arrow Exceptions

## Exceptions to arrow sizing and placement:

Example 1 shows a building floor directory. Active floors displayed in red will display an extended room block of numbers. An arrow is placed on the left as well as the right.

Example 2 shows an interior Numeric Journey Block sign. Arrows are larger on the top core portion of the sign with a right or left arrow height that aligns with the height of a non-rounded number. However, the instructions at the bottom use an arrow that is smaller.

Example 3 uses a design exception in this billboard with larger navigational arrows blocked into columns for greater interpretation at higher vehicular speeds. The vertical arrow's vertical stalk has also been modified for an even horizontal row height across columns.

Example 4 shows a different exception. Exterior Perimeter Lead signage used for vehicular scenarios will have navigational arrows placed in a left-aligned format *above* grouped sections of content (instead of left). This allows for easier comprehension in a blocked format for the sign's use case.

Example 1: Floor directory with arrow on the left and right of room number block (used in red active floor display only).

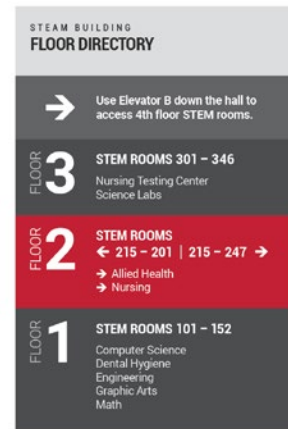

Example 2: Numeric Journey Block signage with appended Instructions Gray Bar at the bottom

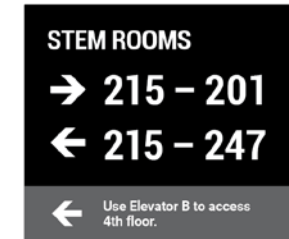

Example 4: Perimeter Lead Signage

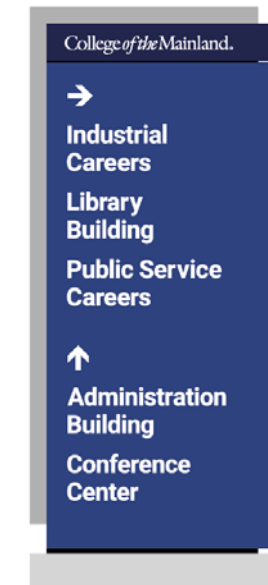

Example 3: Navigational billboard

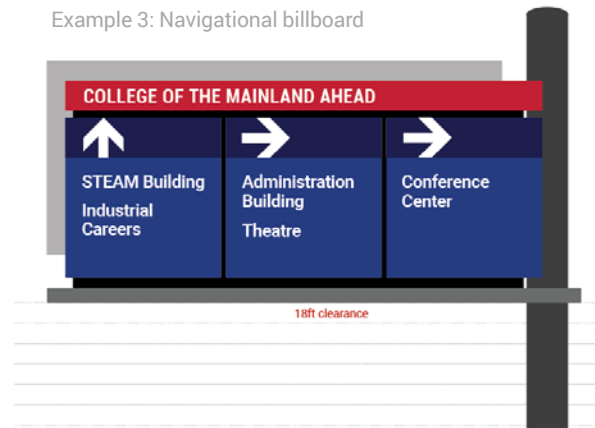

All campus and building signage (including interior, exterior, permanent or temporary) created by internal staff or external parties must be submitted as proofs to the Office of Marketing and Public Affairs for brand approval prior to printing, production, distribution and installation:

[brandapproval@com.edu](mailto:brandapproval@com.edu)

# Signage: Exterior

# Campus Signage Exterior Wayfinding: Building Lettering – Logos

COM Stacked Logo: Doyle Family Administration Building



Exterior facade-mounted COM logos are reserved for strategic points of entry or visibility to the campus and are not intended for use on every building.

COM Stacked Logo: Industrial Careers Building



Exterior facade-mounted COM logos are reserved for strategic points of entry or visibility to the campus and are not intended for use on every building.

All placement of a COM logo will take into account the logo's purpose per usage instance, the building's architecture, logo legibility, integrity, the application of adequate clear space, overall visual composition with the placement. Logo lockup, color and scale may vary per application.

Usage of the COM logo on campus buildings is extremely limited and requires brand approval from the Marketing office.

All campus and building signage (including interior, exterior, permanent or temporary) created by internal staff or external parties must be submitted as proofs to the Office of Marketing and Public Affairs for brand approval prior to printing, production, distribution and installation:

[brandapproval@com.edu](mailto:brandapproval@com.edu)

# Campus Signage Exterior Wayfinding: Building Lettering – Community-Facing

COM Theatre: Fine Arts Building



Community-facing buildings are identified with white-faced, lit channel lettering, in all caps, with black sides using the font Roboto Bold, tracking -20 and are kerned as needed for a professional appearance.

COM Police Station



Community-facing buildings designated within the COM campus include the Police Station and the Theatre. These are identified with white-faced, lit channel lettering, in all caps, left-aligned, with black sides. These signs use the font Roboto Bold set to -20 tracking and are kerned as needed. Scale should be complimentary to the architecture vs. overpowering and may vary in size per building instance.

Placement of this lettering should view the building as an overall composition. Location decisions will align with modern typography principles accounting for dynamic placement, clear space and legibility.

All campus and building signage (including interior, exterior, permanent or temporary) created by internal staff or external parties must be submitted as proofs to the Office of Marketing and Public Affairs for brand approval prior to printing, production, distribution and installation:

[brandapproval@com.edu](mailto:brandapproval@com.edu)

# Campus Signage Exterior Wayfinding: Building Lettering – Donor Naming

Doyle Family Administration Building: 16.25in H channel lettering. Roboto Bold, tracking 90, 5in black depth. See additional details in the right column.



Exterior building donor naming on the college's main campus will follow standardized guidelines to create a cohesive and unified design approach. Naming shall consist of white-faced channel letters, in all caps, created at 16.25 inches high, fabricated aluminum, non-lit with 5 inch deep black sides. These signs use the font Roboto Bold, tracking set to 90 and lettering is kerned as needed for a professional appearance. For instances where 2 or more lines will appear, Marketing will review the font leading settings for those applications.

Letter placement will take into account each building's architecture, typography best practices, legibility, integrity, adequate clear space around the text in relation to architectural elements, overall visual composition and appropriate locations such as soffits or other areas to accommodate proposed lettering. All lettering and its placement on college buildings will require the marketing department's approval before production can begin.

All campus and building signage (including interior, exterior, permanent or temporary) created by internal staff or external parties must be submitted as proofs to the Office of Marketing and Public Affairs for brand approval prior to printing, production, distribution and installation:

[brandapproval@com.edu](mailto:brandapproval@com.edu)

# Campus Signage Exterior Wayfinding: Vehicular Entrance Signs: Type 1

Aluminum signage | Flush screws | Removable panels | Lighted | Concrete base:  
Entrance Signs are located at the four main campus vehicular campus entry points. These display the COM logo, the entrance number and **recommended three major destination points**. Destination point typography should remain simple for clarity and maintain significant clear space along right and left sides.

**4 Paint Colors (CMYK):**  
Light Gray (Fin): 31, 25, 26, 0  
Navy Blue (main panel): 100, 97, 38, 37  
COM Blue (Large number): 100, 87, 20, 11  
Black core (base, vertical sides, top): 0, 0, 0, 100

## FINAL MENU ITEM LIST TBD

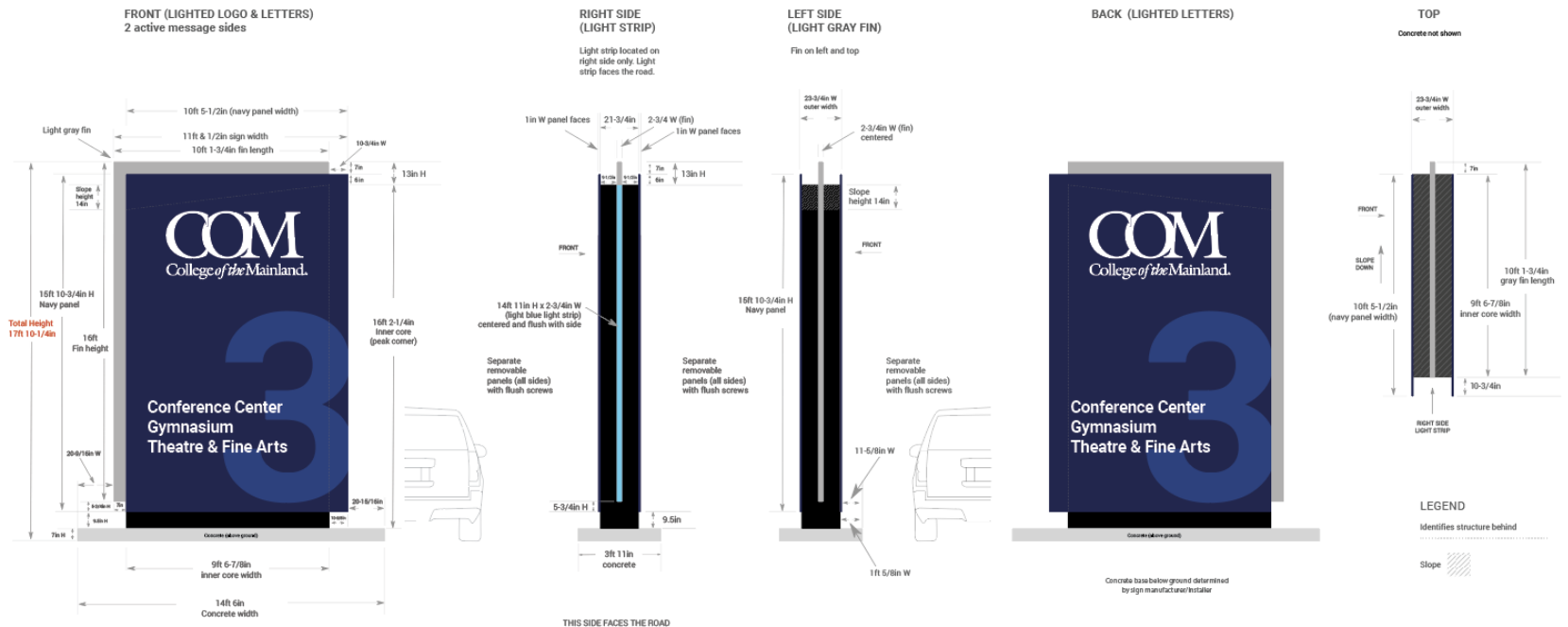



# Campus Signage Exterior Wayfinding: Perimeter Directional Leads

Aluminum signage | Flush screws | Removable panels | Concrete base:  
 Located at strategic points along exterior roadways. Designed for readability at driving speeds.

- MAX: Total of 10 words or 5 journey points per perimeter lead sign
- MAX: 3 journey points per arrowed section
- MAX: 2 lines of text per menu journey point with fixed size font
- Note: Parking lots are purposefully not included on this signage type
- Proximity based sections (but still alphabetical within section)
- Graffiti resistant finish
- Wind rated construction and installation

## 5 Paint Colors (CMYK):

Light Gray (Fin): 31, 25, 26, 0

Navy (Top logo band area)  
 100, 97, 38, 37

COM Blue (Main panel):

100, 87, 20, 11

SW 7674 Peppercorn (Back panel):

63, 55, 54, 29

Black core (base, indent areas, vertical sides, top):

0, 0, 0, 100

Sign Lettering:  
 25 miles per hour = 36.7 feet per second.

5in letters can be viewed at 125ft max. 3.5 seconds max to read the sign.

The average reading speed for the English language is between 170 and 240 wpm (avg 200wpm)

10 words can be read in 2.6 to 3 seconds. (Leave 0.5 second buffer for slower readers or potential 11th word)

**25MPH**  
**~5in letters**  
**Visibility 125ft**

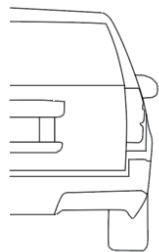

FINAL TEXT TBD

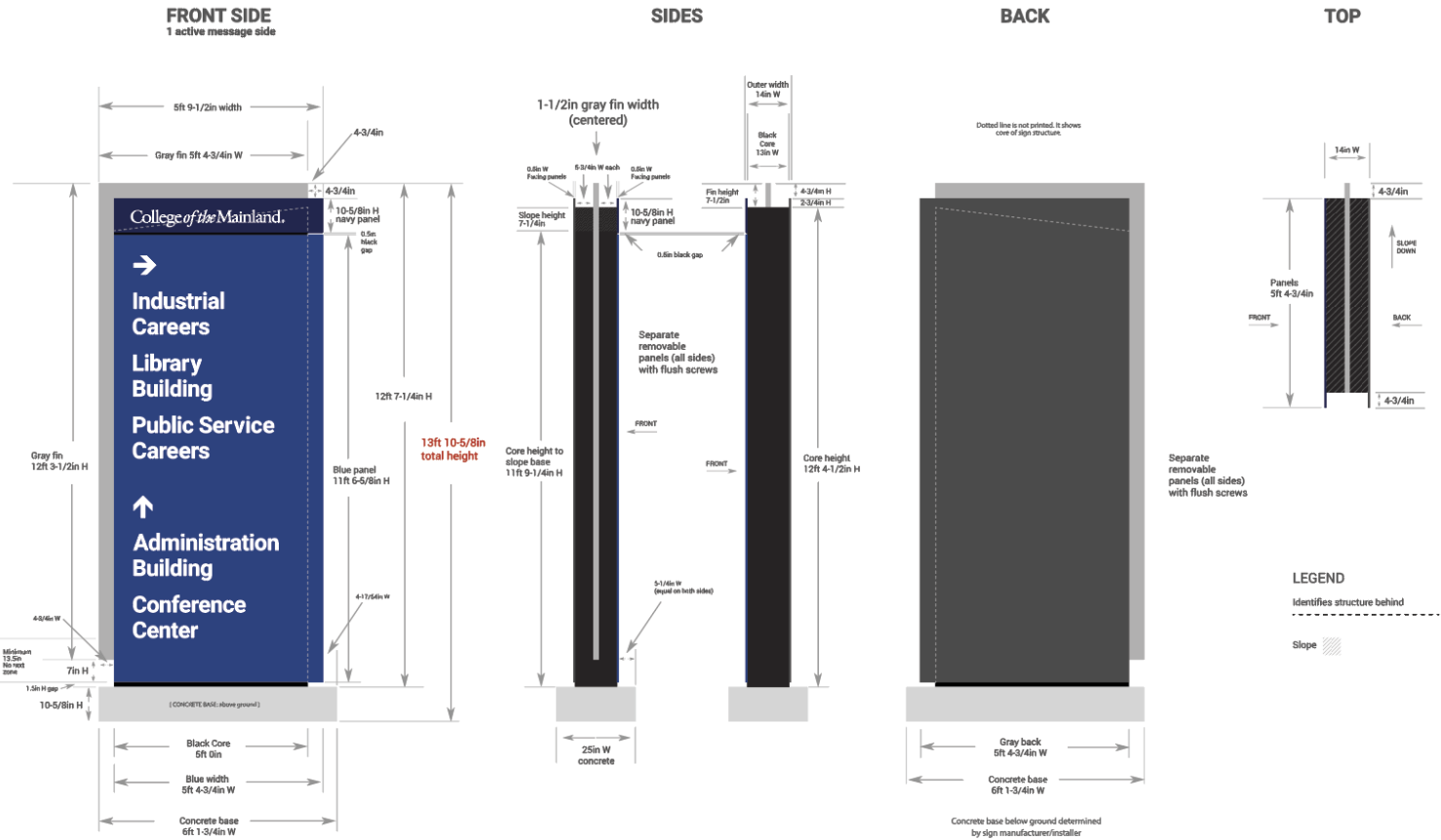

# Campus Signage Exterior Wayfinding: Vehicular Entrance Signs: Type 2

Aluminum signage | Flush screws | Removable panels | Lighted | Concrete base:

Type 2 entrance signs are much smaller than Type 1 signs and located at less dominant vehicular campus entry points. These display the COM logo and no more than two destination points. Destination points should remain simple for clarity and maintain significant clear space along right and left sides.

**4 Paint Colors (CMYK):**  
Light Gray (Fin): 31, 25, 26, 0

Navy Blue (top panel):  
100, 97, 38, 37

COM Blue (panels front and back):  
100, 87, 20, 11

Black (indents, vertical sides, top):  
0, 0, 0, 100

**Sign Lettering:**  
25 miles per hour = 36.7 feet per second.

5in letters can be viewed at 125ft max. 3.5 seconds max to read the sign.

The average reading speed for the English language is between 170 and 240 wpm (avg 200wpm)

6 words can be read in 1.8 seconds. (Leaves almost 2 additional seconds buffer for slower readers or another word)

**25MPH**  
**~5-1/4in letters**  
**Visibility 130ft+**

FINAL TEXT TBD

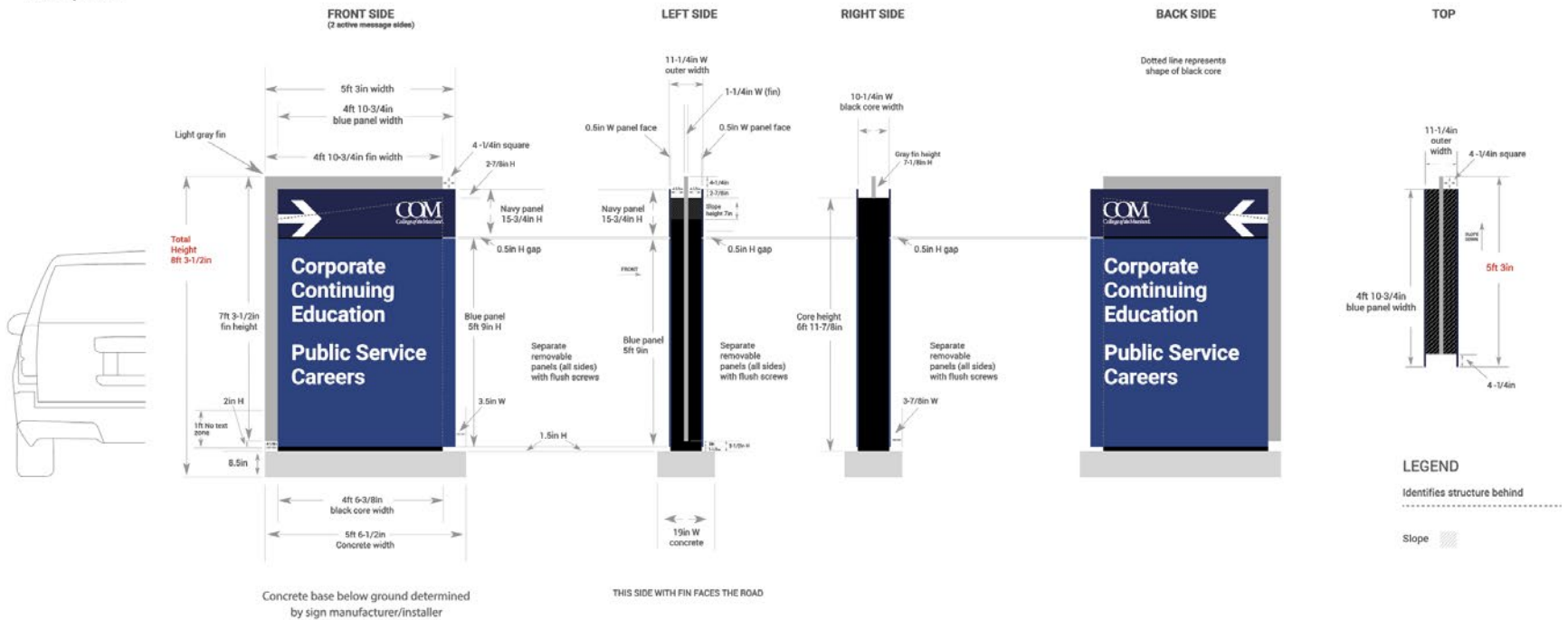

Large arrows used at the top must always have their base "attached" visually whether it be left, right or pointing upwards..

# Campus Signage Exterior Wayfinding: Vehicular Entrance Signs: Type 3

Aluminum signage | Flush screws | Removable panels | Concrete base:

Type 3 entrance signs are used for industrial or authorized uses.

These are less dominant vehicular campus entry points than a Type 2 entrance sign. These display the COM logo and no more than two destination points. Destination points should remain simple for clarity and maintain significant clear space along right and left sides.

**4 Paint Colors (CMYK):**  
Light Gray (Fin): 31, 25, 26, 0

Navy Blue (top panel):  
100, 97, 38, 37

COM Blue (panels front and back):  
100, 87, 20, 11

Black (indents, vertical sides, top):  
0, 0, 0, 100

**Sign Lettering:**  
25 miles per hour = 36.7 feet per second.

3-5/8in letters can be viewed at xxxft max. xx seconds max to read the sign.

The average reading speed for the English language is between 170 and 240 wpm (avg 200wpm)

xx words can be read in xx seconds. (Leaves almost xx additional seconds buffer for slower readers or another word)

**25MPH**  
~3-5/8in letters  
Visibility xxxft+

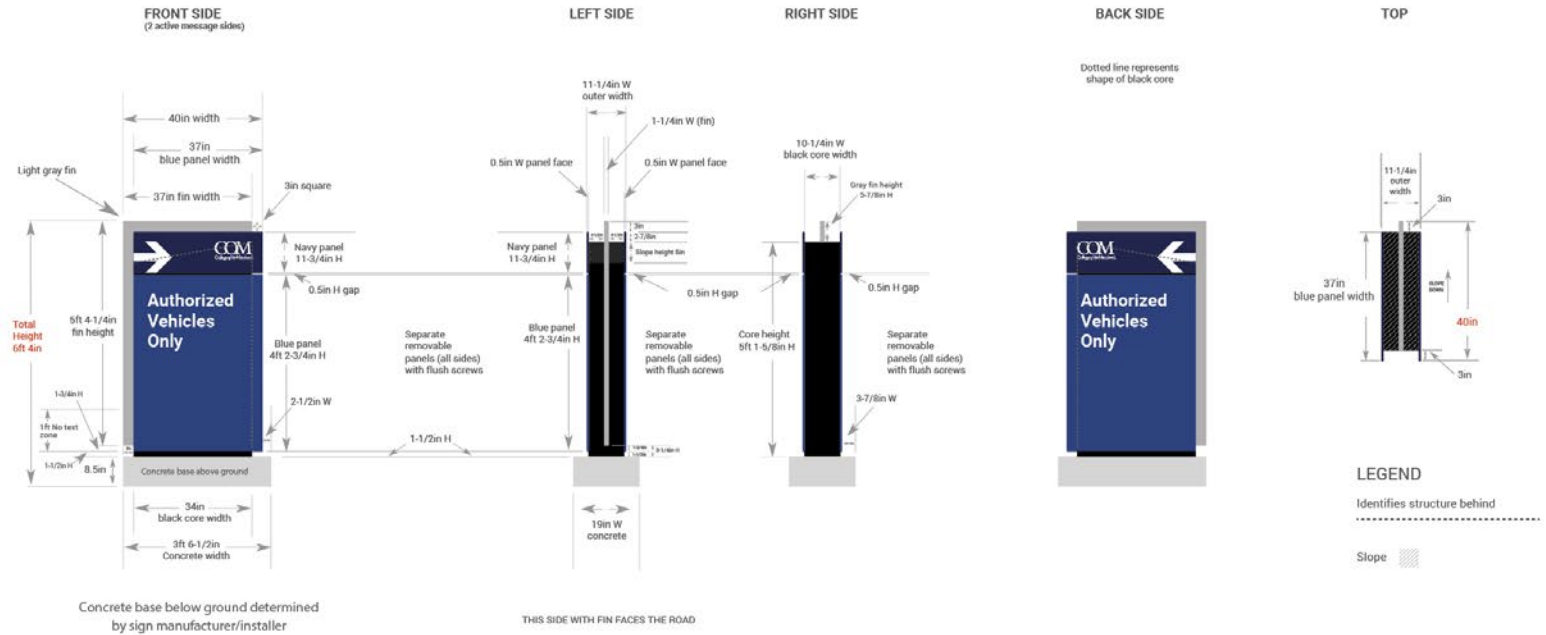
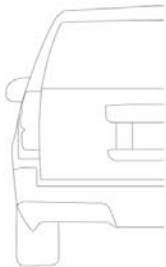

Large arrows used at the top must always have their base "attached" visually whether it be left, right or pointing upwards..

# Campus Signage Exterior Wayfinding: Main Campus Parking Light Pole Identifiers

Square color blocks mounted on light poles in respective parking lots — aligns with parking lot colors as shown below

Paint Colors (CMYK):

Color coded parking lots:

A: Yellow: 2, 32, 91, 0

B: Red: 16, 100, 85, 6

C: Bright Blue: 73, 17, 0, 0

D: Purple: 62, 75, 20, 3

E: Orange: 0, 54, 93, 0

F: Green: 61, 0, 94, 0

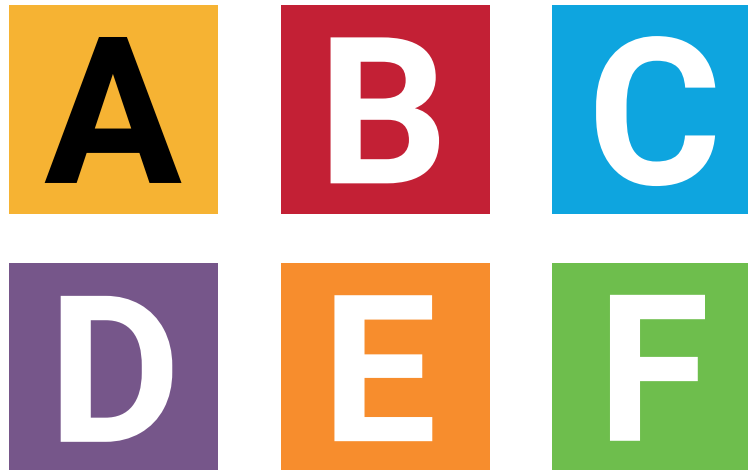

# Campus Signage Exterior Wayfinding: Main Campus Parking Signs: Type 1

Aluminum signage | Flush screws | Removable panels | Non-Lighted | Concrete base:  
Type 1 parking signs are full size and the primary standard size  
MAX: Total of 6 journey points per parking sign  
Maximum 3 journey points per arrowed section  
Slanted top to prevent debris and residue buildup

Type 1 parking signs are full size and the primary standard size.  
MAX: Total of 10 words per parking sign (less is more)  
Ideally no more than 3 journey points per arrowed section  
Sign placement: Before any corresponding turn (i.e., Fred Taylor)  
Proximity based sections (but still alphabetical within section)  
Graffiti resistant finish  
Wind rated construction and installation

FINAL TEXT TBD

**Paint Colors (CMYK):**  
Color coded parking lots:  
A: Yellow: 2, 32, 91, 0  
B: Red: 16, 100, 85, 6  
C: Bright Blue: 73, 17, 0, 0  
D: Purple: 62, 75, 20, 3  
E: Orange: 0, 54, 93, 0  
F: Green: 61, 0, 94, 0

**5 Paint Colors (CMYK):**  
Light Gray (Fin): 31, 25, 26, 0  
Parking Lot ID color (Top band area)  
CMYK for lot color  
Dark gray (front menu panel)  
68, 61, 60, 49  
SW 7674 Peppercorn (back):  
63, 55, 54, 29  
Black core (base, indent areas, vertical sides, top):  
0, 0, 0, 100

**Sign Lettering:**  
10 miles per hour = 14.7 feet per second.

3.5in letters can be viewed at 87ft max. 5.9 seconds max to read the sign.

The average reading speed for the English language is between 170 and 240 wpm (avg 200wpm)

10 words can be read in 2.6 to 3 seconds. (Leaves extra 3 second buffer for slower readers or potential 11th word)

**10MPH**  
**~3-5/8in letters**  
**Visibility ~87ft**

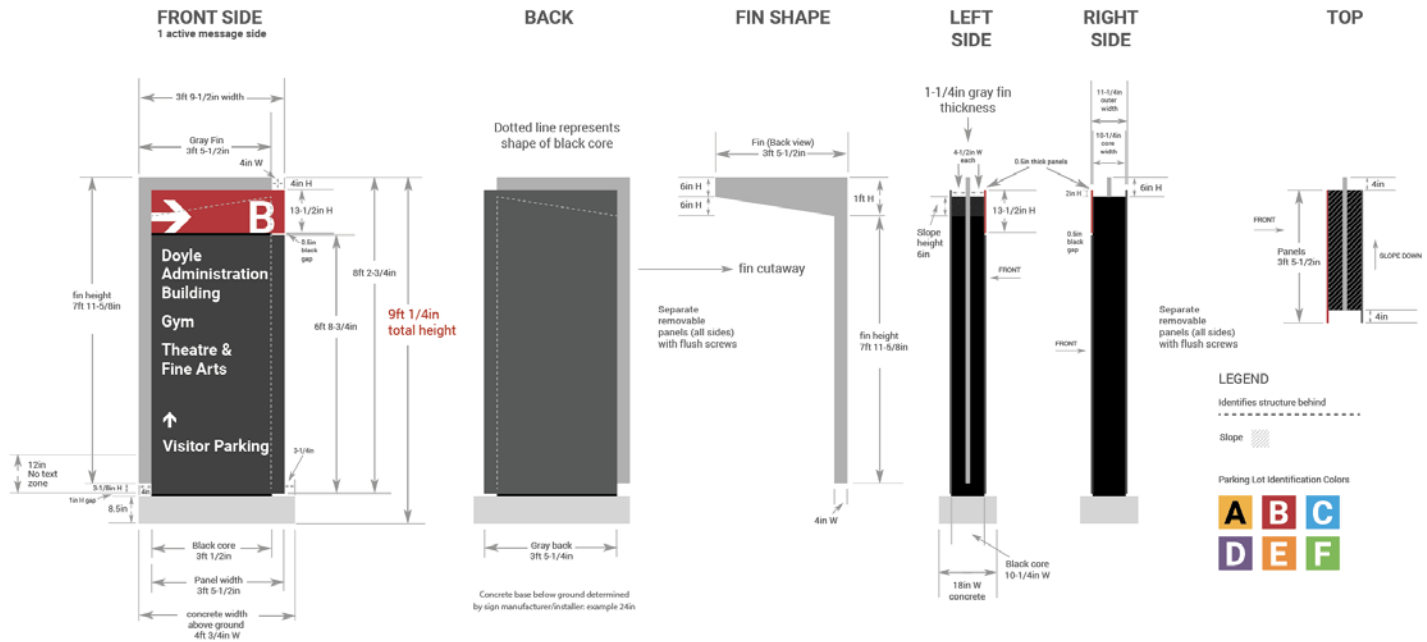
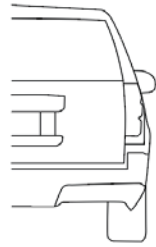

Large arrows used at the top must always have their base "attached" visually whether it be left, right or pointing upwards..

# Campus Signage Exterior Wayfinding: Main Campus Parking Signs: Type 2

Aluminum signage | Flush screws | Removable panels | Non-Lighted | Concrete base:  
Type 2 parking lot signage are full size, but display a limited dual lot menu.  
Slanted top to prevent debris and residue buildup

Type 2 parking signs are full size and the primary standard size.  
Limited menu space due to dual stack  
MAX: Total of 6 words per parking sign  
MAX: 2 journey points per lot designation  
Sign placement: Before any corresponding turn (i.e., Fred Taylor)  
Proximity based sections (but still alphabetical within section)  
Grafitti resistant finish  
Wind rated construction and installation

Paint Colors (CMYK):  
Color coded parking lots:  
A: Yellow: 2, 32, 91, 0  
B: Red: 16, 100, 85, 6  
C: Bright Blue: 73, 17, 0, 0  
D: Purple: 62, 75, 20, 3  
E: Orange: 0, 54, 93, 0  
F: Green: 61, 0, 94, 0

**10MPH**  
**~3-5/8in letters**  
**Visibility ~87ft**

FINAL TEXT TBD

5 Paint Colors (CMYK):  
Light Gray (Fin): 31, 25, 26, 0  
Parking Lot ID color (Top band area)  
CMYK for lot color  
Dark gray (front menu panel)  
68, 61, 60, 49  
SW 7674 Peppercorn (back):  
63, 55, 54, 29  
Black core (base, indent areas, vertical sides, top):  
0, 0, 0, 100

Sign Lettering:  
10 miles per hour = 14.7 feet per second.

3.5in letters can be viewed at 87ft max. 5.9 seconds max to read the sign.

The average reading speed for the English language is between 170 and 240 wpm (avg 200wpm)

10 words can be read in 2.6 to 3 seconds. (Leaves extra 3 second buffer for slower readers or potential 11th word)

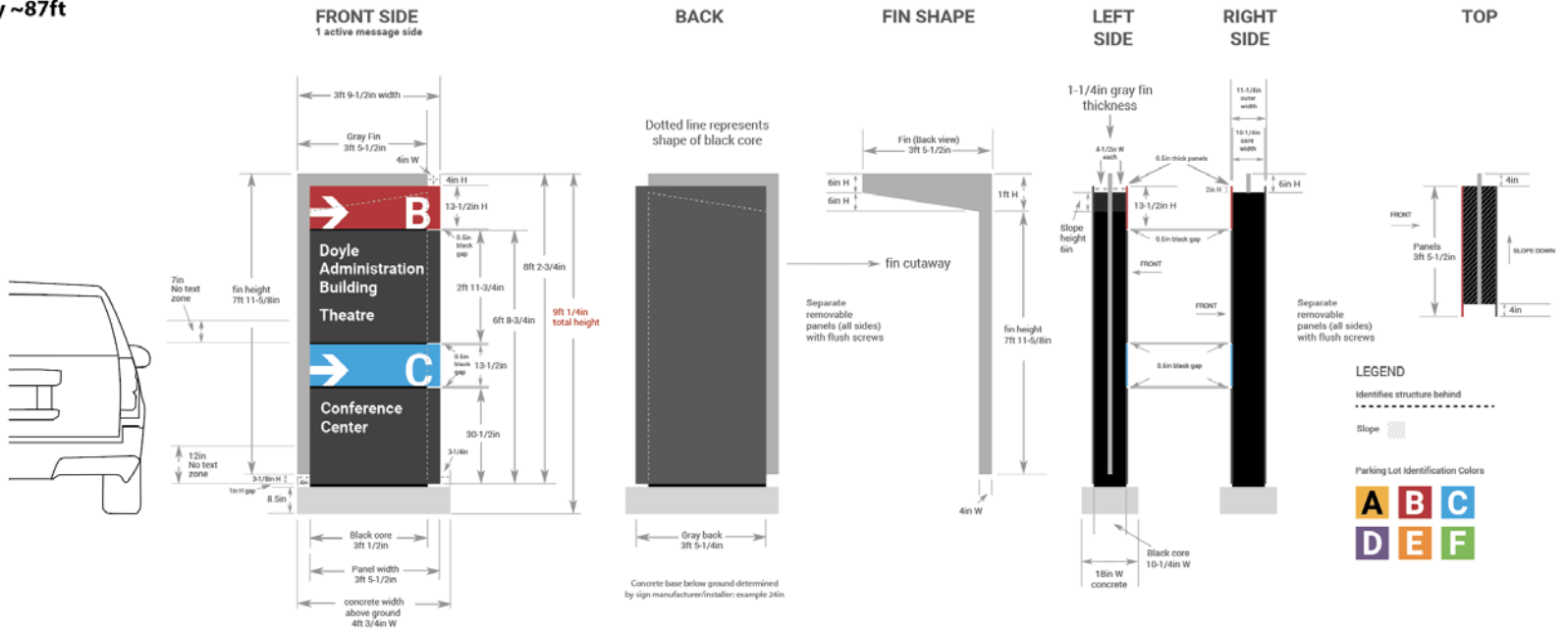

Large arrows used at the top must always have their base "attached" visually whether it be left, right or pointing upwards..

# Campus Signage Exterior Wayfinding: Main Campus Parking Signs: Type 3 Variations

Aluminum signage | Flush screws | Removable panels | Non-Lighted | Concrete base:  
Type 3 parking signs are smaller-size for inner lot connectivity  
Slanted top to prevent debris and residue buildup

Type 3 parking signs are a smaller size.

Limited menu space due to dual stack

MAX: Total of 6 words per sign

MAX: 3 journey points per lot designation (if 3, all single line)

Sign placement: Parking lot connectivity and roundabouts

Graffiti resistant finish

Wind rated construction and installation

**Paint Colors (CMYK):**  
Color coded parking lots:  
A: Yellow: 2, 32, 91, 0  
B: Red: 16, 100, 85, 6  
C: Bright Blue: 73, 17, 0, 0  
D: Purple: 62, 75, 20, 3  
E: Orange: 0, 54, 93, 0  
F: Green: 61, 0, 94, 0

**10MPH**  
**~3-5/8in letters**  
**Visibility ~87ft**

**5 Paint Colors (CMYK):**  
Light Gray (Fin): 31, 25, 26, 0  
Parking Lot ID color (Top band area)  
CMYK for lot color  
Dark gray (front menu panel)  
68, 61, 60, 49  
SW 7674 Peppercorn (back):  
63, 55, 54, 29  
Black core (base, indent areas, vertical sides, top):  
0, 0, 0, 100

**Sign Lettering:**  
10 miles per hour = 14.7 feet per second.

3.5in letters can be viewed at 87ft max. 5.9 seconds max to read the sign.

The average reading speed for the English language is between 170 and 240 wpm (avg 200wpm)

6 words (max) can be read in 1.8 seconds. (Leaves extra 4.1 second buffer for slower readers)

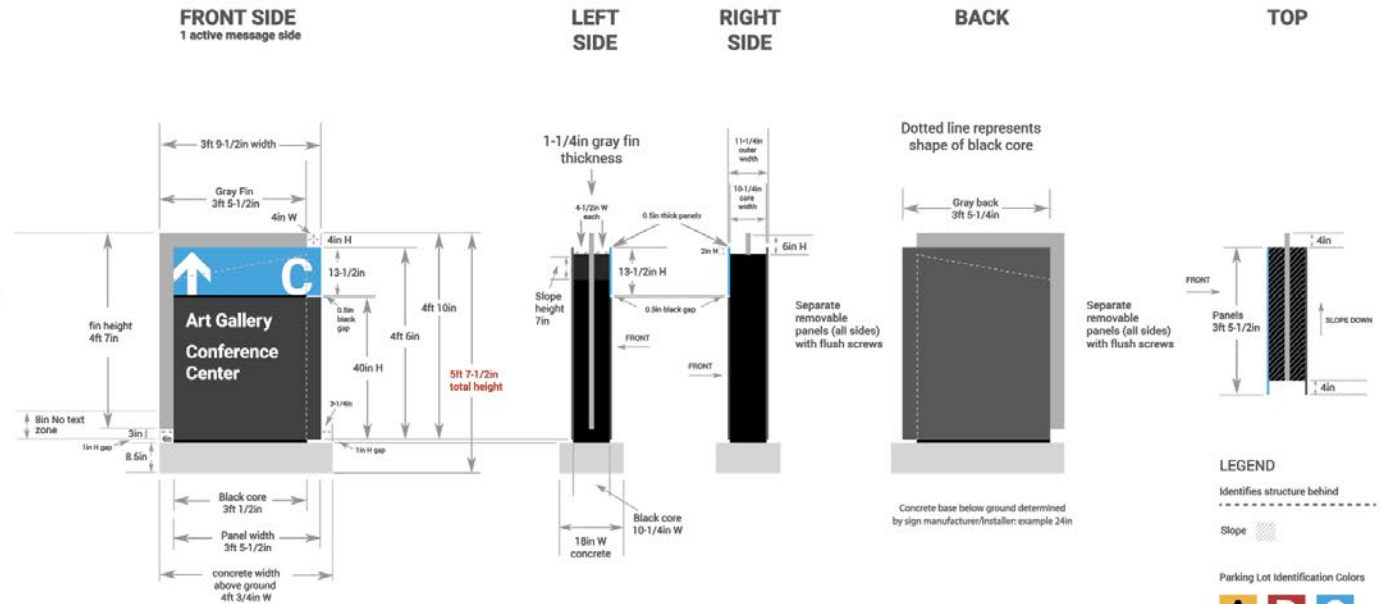
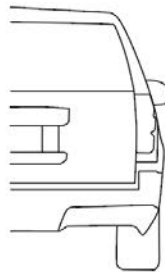

Lot B to C connectivity roadway

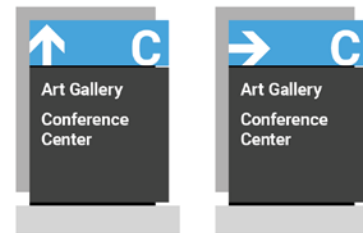

Roundabout example: Lot C entrance

Large arrows used at the top must always have their base "attached" visually whether it be left, right or pointing upwards..

# Campus Signage Exterior Wayfinding: Main Campus Parking Signs: Type 4

Aluminum signage | Flush screws | Removable panels | Non-Lighted | Concrete base:  
Type 4 parking signage – Single journey point reinforcement (i.e., Visitor parking)  
MAX: Total of 1 journey point per parking sign

Single message – visitor

# COMING SOON



# Campus Signage Exterior Wayfinding: Main Campus Monument Maps

Aluminum signage | Flush screws | Removable panels | Concrete base:  
 Monument Maps are located at pedestrian inner campus entry points (Parking lot to campus paths). These contain custom QR codes linking to specific orientation maps online. The bottom portion of the sign acts as an additional wayfinding element guiding viewers to other campus destinations. If parking indication is included in this bottom menu it appears first within each arrowed section.

- MAX: 5 journey points in lower menu (aside from Parking)
- MAX: 1 line of text per lower menu journey point
- Proximity based sections (but still alphabetical within section)
- Graffiti resistant finish
- Wind rated construction and installation

## 5 Paint Colors (CMYK):

Light Gray (Fin): 31, 25, 26, 0

COM Red (Top panel):

16, 100, 86, 7

Dark Gray (Mid panel):

68, 61, 60, 49

SW 7674 Peppercorn (lower panel):

63, 55, 54, 29

Black core (base, indent areas, vertical sides, top): 0, 0, 0, 100

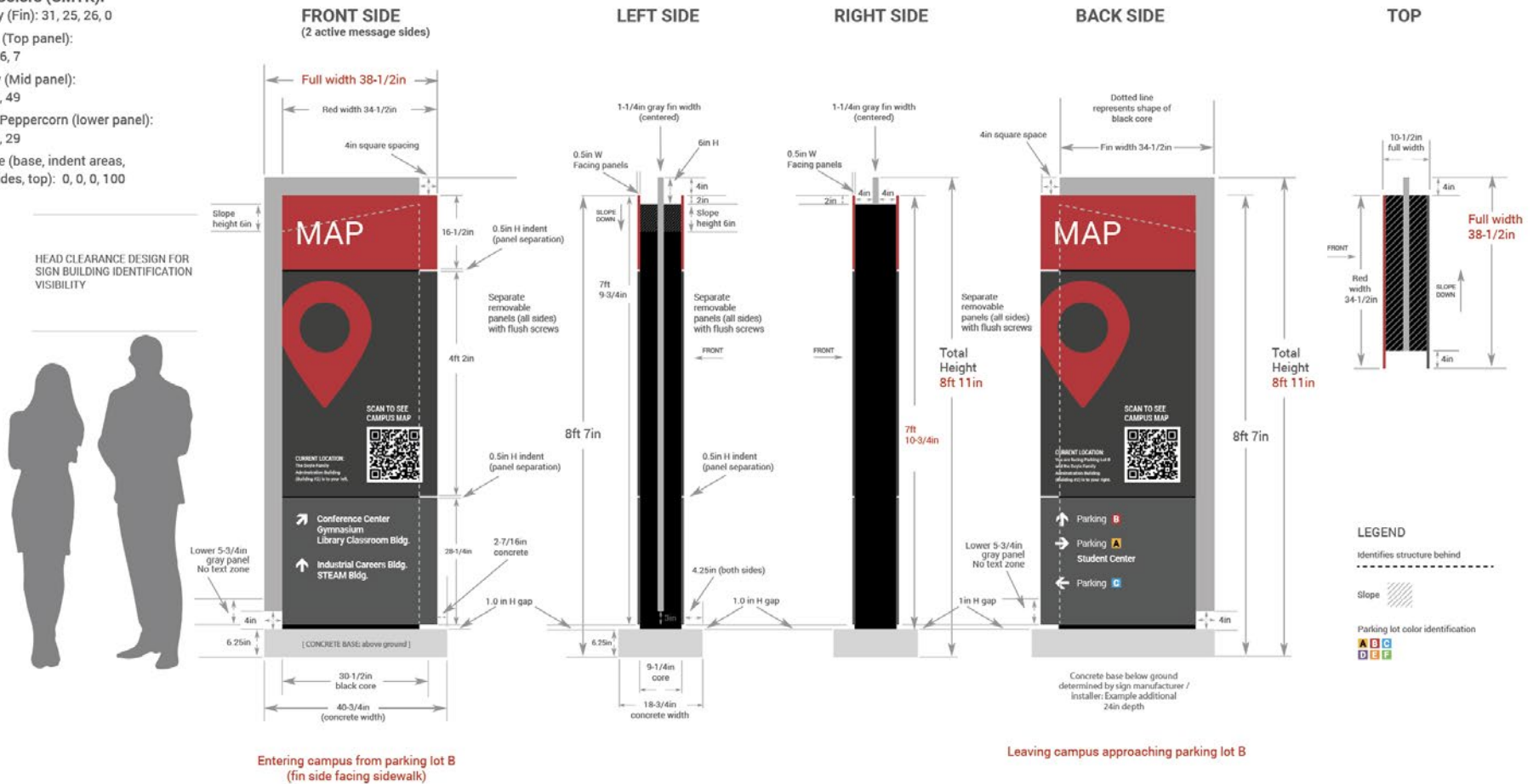

# Campus Signage Exterior Wayfinding: Main Campus Foot Traffic

Aluminum signage | Flush screws | Removable panels | Concrete base:

Foot traffic signs are pedestrian guidance points. These may be located along sidewalks within the inner campus, or along pedestrian pathways in parking lots.

Content amount is determined following standard spacing: clear space (on all sides around content as well as content separation distances, bottom no text zone – see visual layer), font size, and leading

Est. 20 character count per line max

“Parking” is written in Roboto Regular, Journey Points are written in bold.

Font sizes and parking lot color square sizes are fixed

Font size and lot color squares in this sign type are the same size in Monument signage (IDs and Maps)

Red panel across bottom stating no firearms or tobacco

## FINAL TEXT TBD

### 3 Paint Colors (CMYK):

SW Peppercorn (text panels):  
CMYK: 63, 55, 54, 29

Red notice (across bottom):

CMYK: 16, 100, 85, 6

Black (indents, vertical sides, top):

CMYK: 0, 0, 0, 100

**WALKING**  
~1-3/8in letters  
Visibility 5-25ft

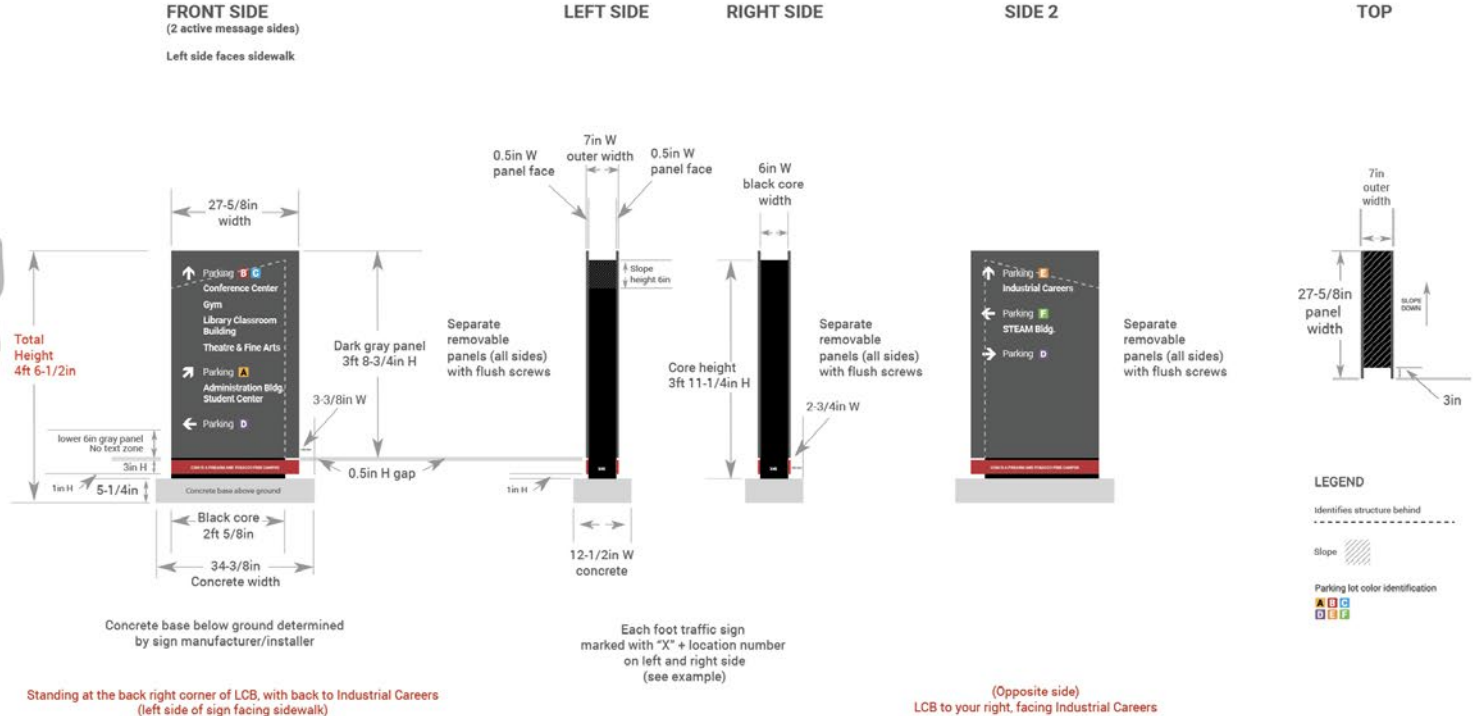

# Campus Signage Exterior Wayfinding: Main Campus Building Monument IDs

Aluminum signage | Flush screws | Removable panels | Concrete base:  
 Monument IDs are located only at building entrances and include the building number, building name and a list of notable journey points within the building. The bottom portion of the sign acts as an additional wayfinding element guiding viewers to other nearby or prominent campus destinations. If parking indication is included in this bottom menu it appears first within each arrowed section.

- MAX: 6 journey points in lower menu
- Building journey points list (within) ideally limit to one line
- MAX: 1 line of text per lower menu journey point
- Proximity based sections (but still alphabetical within section)
- Placed at building entrances only (to the right in most cases)
- Graffiti resistant finish
- Wind rated construction and installation

## 4 Paint Colors (CMYK):

Light Gray (Fin): 31, 25, 26, 0

COM Blue (Upper panel):

100, 87, 20, 11

SW 7674 Peppercorn (lower panel, back):

63, 55, 54, 29

Black core (base, indents, vertical sides, top):

0, 0, 0, 100

FINAL TEXT TBD

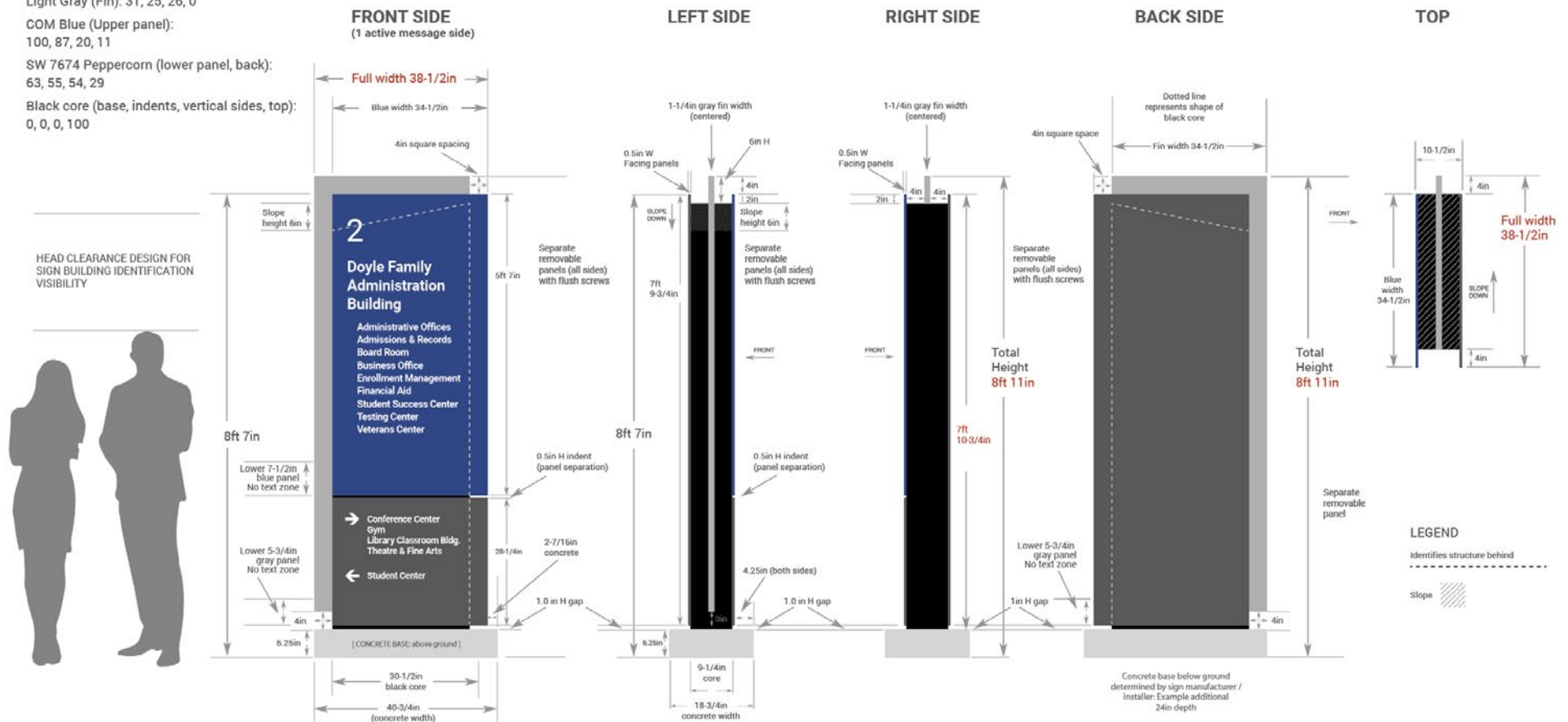

Front of Admin Building on concrete sidewalk to the left of the stairs and entrance door

# Campus Signage Exterior: Hours of Operation

Hours of Operation notification signage is limited to major community-facing points of interest such as the Doyle Family Administration Building, the COM Gym and the Dental Hygiene suite in the STEAM Building. Signage application types include white vinyl on glass and dibond mounted on brick.

All campus and building signage (including interior, exterior, permanent or temporary) created by internal staff or external parties must be submitted as proofs to the Office of Marketing and Public Affairs for brand approval prior to printing, production, distribution and installation:

[brandapproval@com.edu](mailto:brandapproval@com.edu)

## Door glass or window vinyl application:

Must allow for at least 6 inches of clear space on the right and left of the title (from the text's edge to the frame edge of the glass)

Day Font:  
Roboto Bold,  
white, 135.5pt,  
193.5pt leading,  
tracking -20,  
center-aligned

Hours of  
Operation Font:  
Roboto Bold,  
white, 171pt,  
202.5pt leading,  
tracking -20,  
center-aligned

243pt leading  
vertical gap for  
the second set  
of days

Time Font:  
Roboto Bold,  
white, 132.7pt,  
146pt leading,  
tracking -20,  
center-aligned

**Hours of Operation**  
**Monday - Tuesday**  
**8 a.m. - 7 p.m.**  
**Wednesday - Friday**  
**8 a.m. - 5 p.m.**

# Campus Signage Exterior: External College Facilities

This ground sign design is for external COM facilities only.



All COM branch locations use an isolated COM logo identification on the building. Marketing will determine a stacked or horizontal logo use and its scale and placement.

Signs denoting a city-specific location (i.e., League City) will appear on ground signs only.

Formally and for legal purposes, the League City location shall be referred to as "COM League City." Informally it is referred to as the "COM League City facility."

## Ground Sign (Double sided):

- Total Length: 15ft 3.5in
- Total Height: 4ft 1/8in
- Total Width: 2ft 4.5in
- Lighted lettering (consistent glow)
- Indirect light blue glow lighting
- Blue: CMYK 100, 87, 20, 11
- Silver: CMYK 36, 29, 28, 0

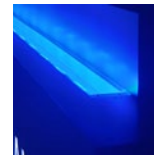

## SIDE VIEW



Design by Carl Owens. Copyright College of the Mainland.

External college facilities are separate locations away from the main campus but will align with core branding guidelines.

Building facades of external facilities are reserved for the display of the COM logo only. The logo will be constructed as white channel letters with black sides. Sizes will vary to align with design and architectural considerations.

The location of external facilities, such as a city name (i.e., "League City"), shall be displayed on the ground-level only.

At night, a light blue indirect back light shines up from behind the center dark blue band, emitting on the top and bottom silver areas (on both sides). All of the letters/logo will light up in white. All areas of the lettering will be constructed so as to appear solid white vs an inconsistent strength. Both sides of the ground sign are identical regardless of the travel direction.

All COM facilities requiring a ground sign with accommodating parameters will align with the League City ground sign design specifications.

All external facility signage, address markings, building facade colors, and all other visual aspects require brand approval from the Marketing office prior to implementation.

# Campus Signage Exterior: External College Facilities (Mall)

## Mainland City Centre External Facility

All COM branch locations use an isolated COM logo identification on the building. Marketing will determine a stacked or horizontal logo use and its scale and placement.

# COMING SOON

External college facilities are separate locations away from the main campus but will align with core branding guidelines.

Building facades of external facilities are reserved for the display of the COM logo only. The logo will be constructed as white channel letters with black sides. Sizes will vary to align with design and architectural considerations.

All external facility signage, address markings, building facade colors, and all other visual aspects require brand approval from the Marketing office prior to implementation.

# Signage: Interior

Common Applications Across All Buildings

# Campus Signage Interior: Room Plaque Color Identification

## Accent Stripes:



P1

SW 6244  
NAVAL

## Material Colors:



M1

FORMICA  
FOLKSTONE  
927-58



M2

FORMICA  
BURNT STRAND  
6307-58

All campus and building signage (including interior, exterior, permanent or temporary) created by internal staff or external parties must be submitted as proofs to the Office of Marketing and Public Affairs for brand approval prior to printing, production, distribution and installation:

[brandapproval@com.edu](mailto:brandapproval@com.edu)



# Campus Signage Interior Wayfinding: Floor Stairwell Wall Plaques

14in W X 15in H Floor Stairwell Sign Specifications:

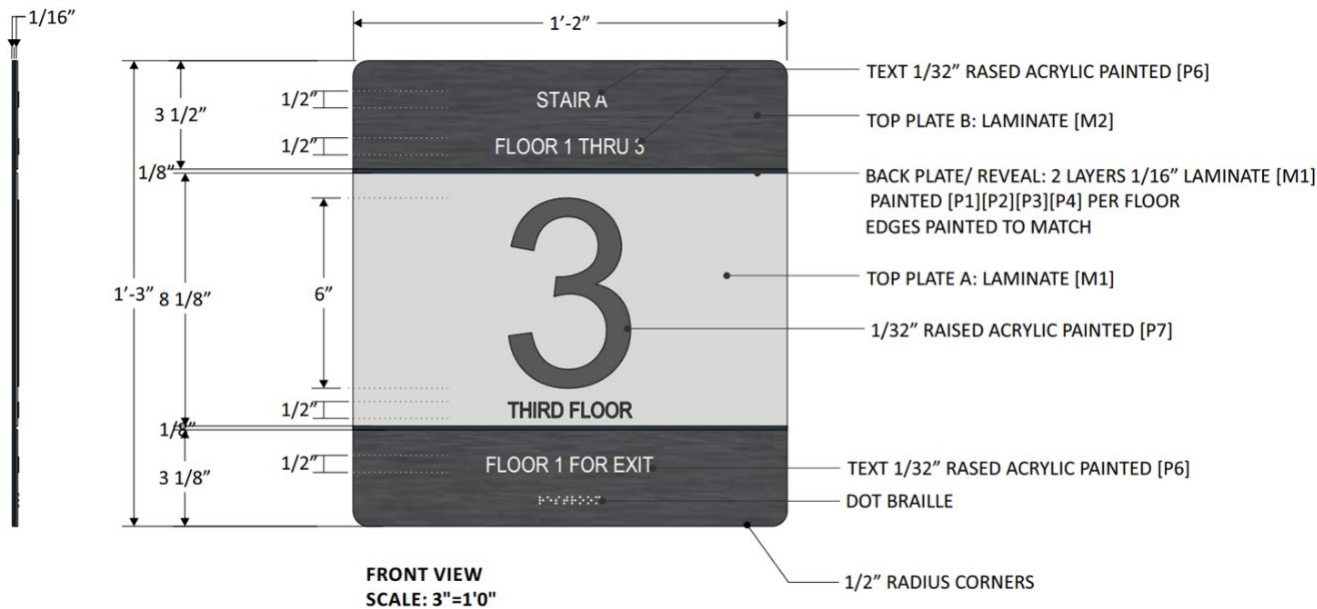

In general, most applications of wayfinding are not center-aligned, but wall plaques (floors and rooms) are an exception.

All campus and building signage (including interior, exterior, permanent or temporary) created by internal staff or external parties must be submitted as proofs to the Office of Marketing and Public Affairs for brand approval prior to printing, production, distribution and installation:

[brandapproval@com.edu](mailto:brandapproval@com.edu)

Accent Stripe Color:



P1

SW 6244  
NAVAL

# Campus Signage Interior Wayfinding: Room ID Wall Plaques

6in X 6in Insert Style and Solid Style Room ID Plaques:

## Room ID Plaque (6x6in): Insert Style

Room Number: Arial, 64.95pt  
Room Number Color: #FFFFFFF  
Braille Font: BrailleKiama, 26.62pt  
Braille Font Color (Line Color): #000000

\*Inserts must be created by the Marketing Dept.

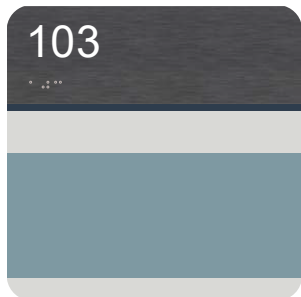

## Room ID Plaque (6x6in): Solid Style (Single line of text)

Room Number: Arial, 64.95pt  
Room Number Color: #FFFFFFF  
Room Name: Arial, 57.46pt  
Braille Font: BrailleKiama, 26.62pt  
Braille Font Color (Line Color): #000000

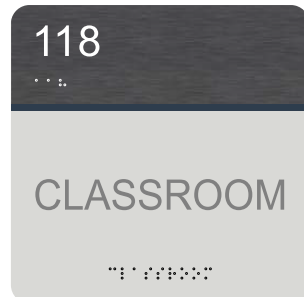

## Room ID Plaque (6x6in): Solid Style (Two rows of text)

Room Number: Arial, 64.95pt  
Room Number Color: #FFFFFFF  
Braille Font Number Color (Line Color): #FFFFFFF  
Room Name: Arial, 57.46pt, Leading 68.95pt  
Room Name Color: #808080  
Braille Font: BrailleKiama, 26.62pt, Leading 31.94pt  
Braille Font Room Name Color (Line Color): #000000

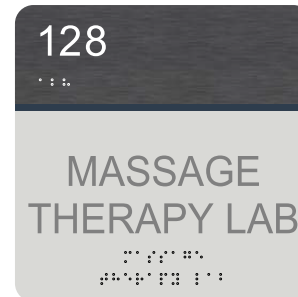

Room plaques will follow a consistent design, standards and appearance throughout all COM facilities.

All room plaques will be ADA compliant. Insert Style plaques will contain both a visual room number and braille room number. Solid Style plaques will contain a visual number and room identification as well as braille for visual markings.

Fonts for all plaques shall remain consistent in font type, size, color and style.

Insert Style and Solid Style room plaques include a thin colored stripe designated by the floor number the plaque appears on. See the stripe color floor reference chart below. In general, most applications of wayfinding are not center-aligned, but wall plaques (floors and rooms) have exceptions.

Room plaque inserts are created and managed by the Marketing department. Please submit a marketing request for new insert labels.

All campus and building signage (including interior, exterior, permanent or temporary) created by internal staff or external parties must be submitted as proofs to the Office of Marketing and Public Affairs for brand approval prior to printing, production, distribution and installation:

[brandapproval@com.edu](mailto:brandapproval@com.edu)

## 6x6 Plaque Accent Stripe Color

All 6x6 room plaques (insert style or solid style) include a thin accent colored stripe. This color code applies to plaques used in all buildings and facilities.

Example:  
Stripe Accent  
Color: SW 6244

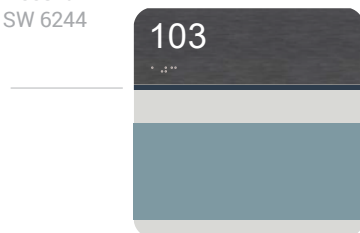

## Accent Stripe Color:

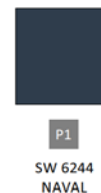

# Campus Signage Interior Wayfinding: Room ID Insert Style Wall Plaques

6in X 6in Insert Style Plaque Specifications:

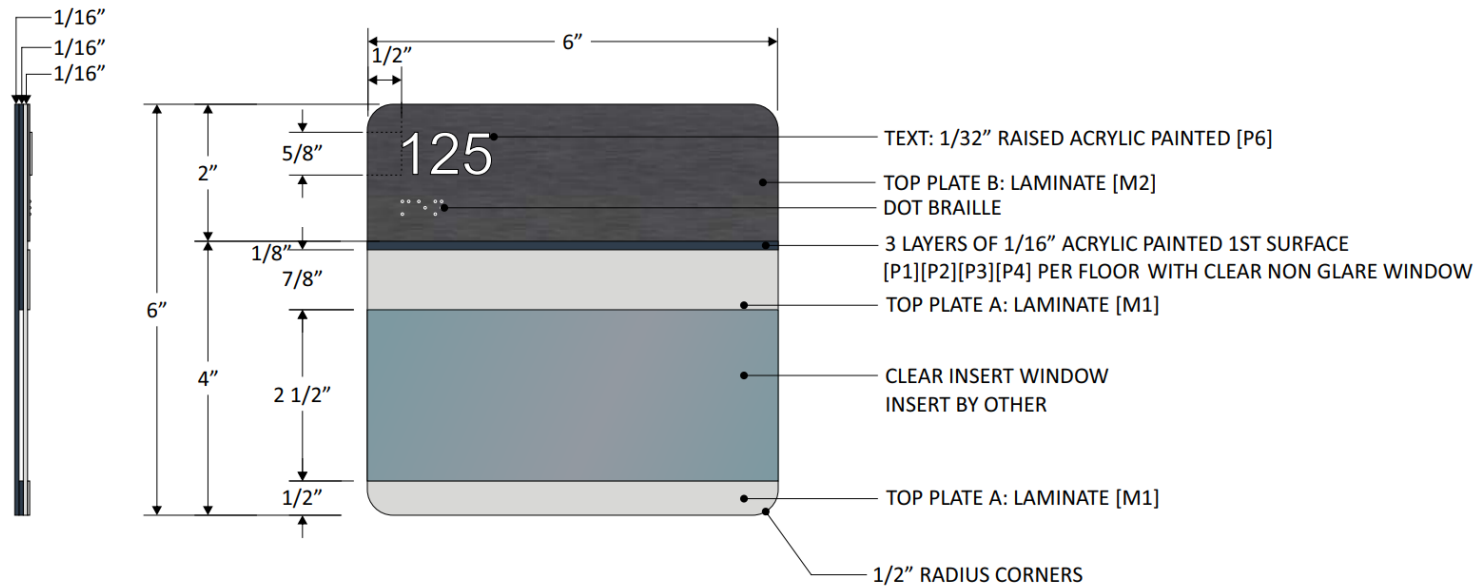

All campus and building signage (including interior, exterior, permanent or temporary) created by internal staff or external parties must be submitted as proofs to the Office of Marketing and Public Affairs for brand approval prior to printing, production, distribution and installation:

[brandapproval@com.edu](mailto:brandapproval@com.edu)

# Campus Signage Interior: Room ID Insert Style Plaque Labels

All insertable labels for use in room plaques will be created by the Marketing department to maintain a cohesive and unified appearance across all campus and facility interiors. All inserts will use one of 3 standardized options shown below. Two of these options are designed for employees displaying name, title and department, and one is to designate non-permanent room usage.

## Employee Offices:

Single line name, single line title and single line department



Double lined name, single line title and single line department



## Non-permanent Rooms:

Description will designate current room usage. Lettering will be displayed at 33pt with 34pt leading not to exceed two lines.



Note: Rooms with a usage or purpose that will never change use a Solid Style plaque.

All Insert Style room plaques will use official insertable labels created by the marketing department to ensure a cohesive brand appearance is maintained across the college campus and its external facilities.

Each insert label will serve only one purpose displaying either:

- 1) one employee's name, their official title and department or
- 2) designation of a room whose purpose may potentially change in the foreseeable future displaying a short description not to exceed two lines of text.

Lettering will be displayed in all caps, center-aligned and positioned with adequate clear space created by the Marketing office. In general, most applications of wayfinding are not center-aligned, but this is one exception. Font sizes, colors and styling must remain consistent at all times and cannot vary per plaque. The word "Department" will be included following all department names for clarity and to avoid awkward display patterns on short department names (i.e., Nursing Department). Kerning will be applied as necessary. All insertable labels will be printed on white paper with a light gray box.

Employee names may only use a first and last name. Names will not contain honorifics, \*middle names, post-nominal letters or other additions. Employee position titles must use the official title granted upon employment. Employees who officially go by an initial-based first name may display it (i.e., R.E. Davis, H. Russ Brown). A middle name or initial may be used as space allows. Suffixes may be included (Jr., Sr., III, etc).

Receptionist areas that do not have a wall-mounted room plaque will not use insert labels. These areas will purchase and use a professional-looking, non-adhesive and free-standing desk name plate of their choice.

Need a new room plaque insert label? Please submit a marketing request containing information needed. Please email questions to:

[brandapproval@com.edu](mailto:brandapproval@com.edu)

# Campus Signage Interior Wayfinding: Room ID Solid Style Wall Plaques

6in X 6in Solid Style Plaque Specifications:

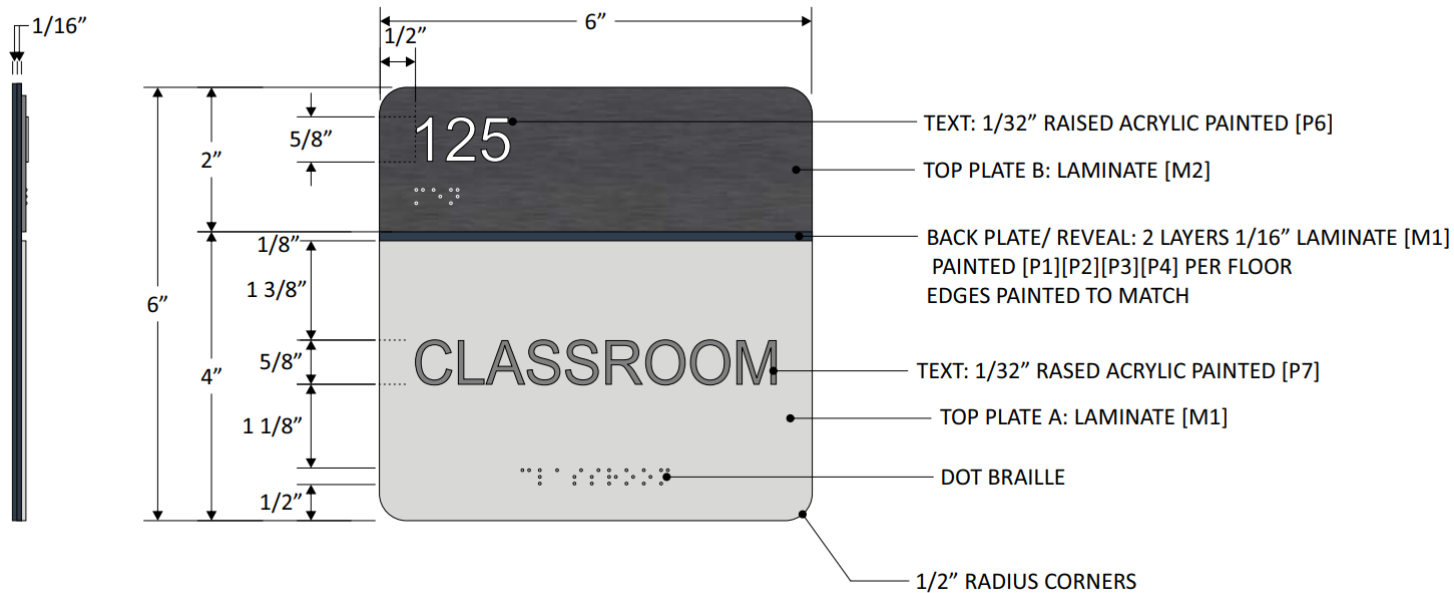

All campus and building signage (including interior, exterior, permanent or temporary) created by internal staff or external parties must be submitted as proofs to the Office of Marketing and Public Affairs for brand approval prior to printing, production, distribution and installation:

[brandapproval@com.edu](mailto:brandapproval@com.edu)

# Campus Signage Interior Wayfinding: Restroom Wall Plaques

## 8in X 8in Plaque: Restroom, Family and Lactation Room Specifications

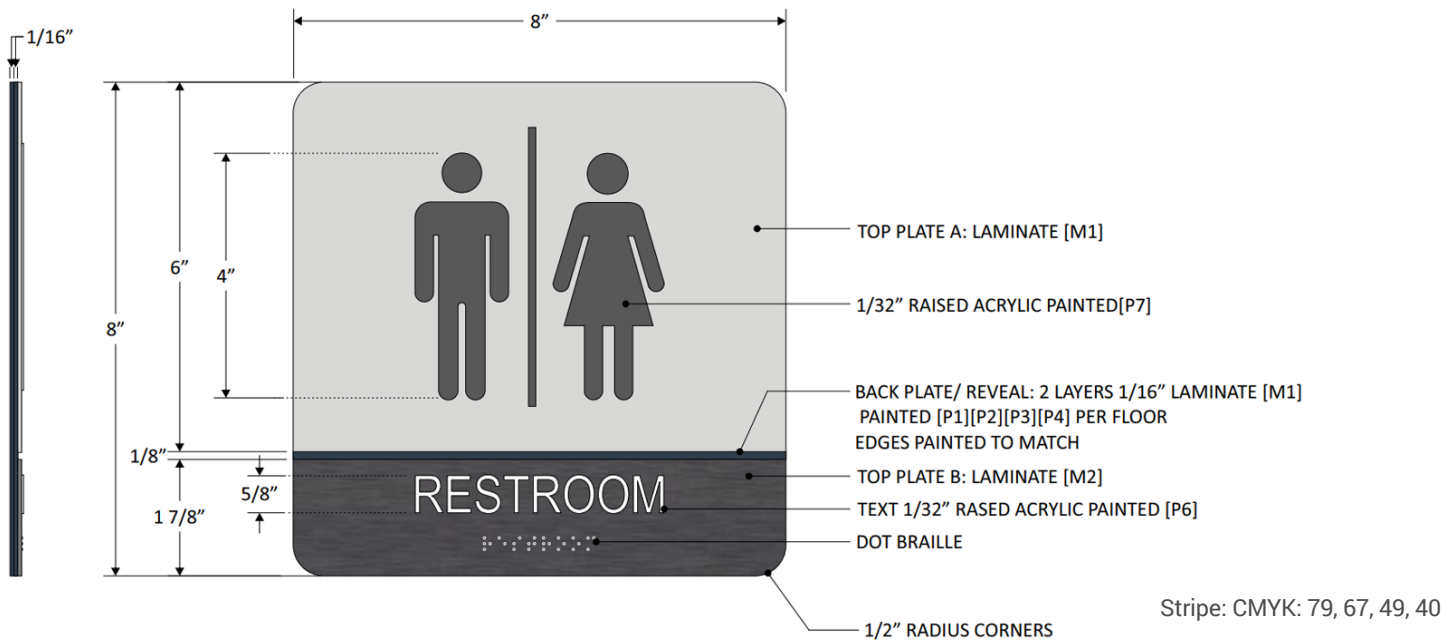

Example: "Family" restroom



Example: "Lactation" room



Accent Stripe Color:

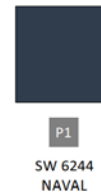

All campus and building signage (including interior, exterior, permanent or temporary) created by internal staff or external parties must be submitted as proofs to the Office of Marketing and Public Affairs for brand approval prior to printing, production, distribution and installation:

[brandapproval@com.edu](mailto:brandapproval@com.edu)

# Campus Signage Interior Wayfinding: Restroom Wall Plaques

8in X 8in Plaque "Men" & "Women" Specifications:

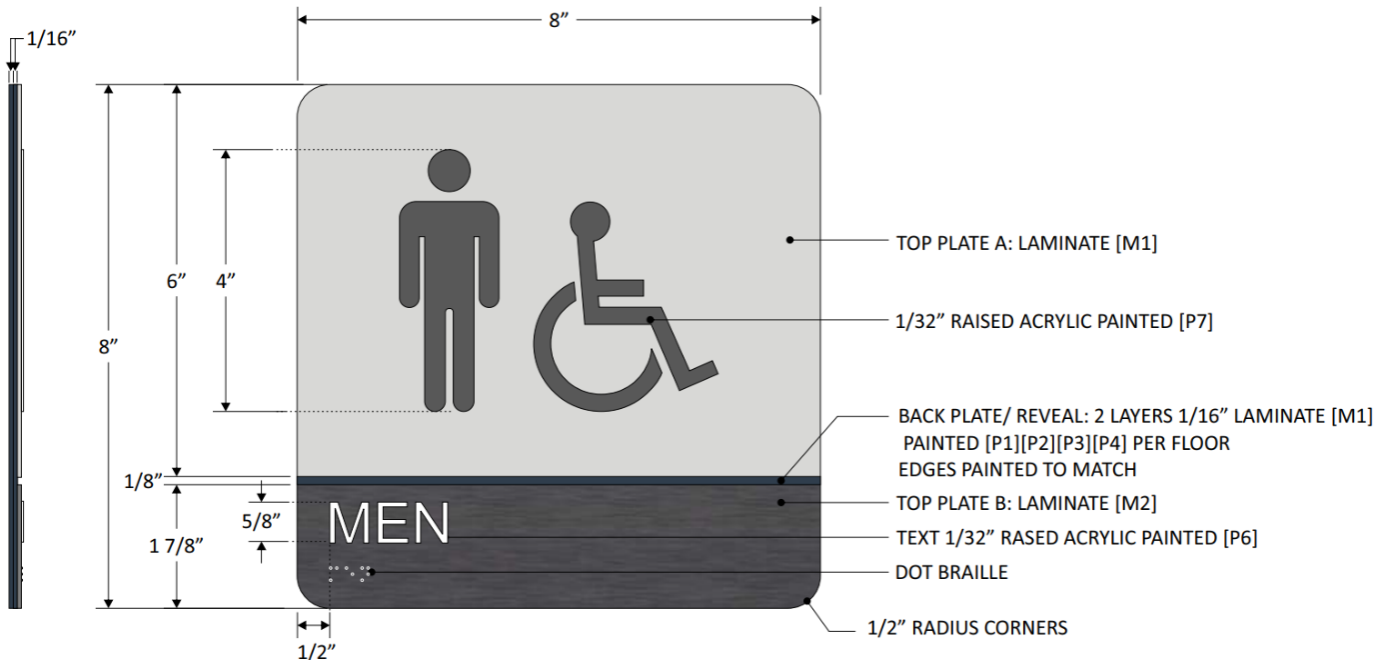

Accent Stripe Color:



P1

SW 6244  
NAVAL

All campus and building signage (including interior, exterior, permanent or temporary) created by internal staff or external parties must be submitted as proofs to the Office of Marketing and Public Affairs for brand approval prior to printing, production, distribution and installation:

[brandapproval@com.edu](mailto:brandapproval@com.edu)





# Campus Signage Interior Wayfinding: Back of House Fire Alarm Control Panel (FACP)

## Fire Alarm Control Panel Signage Specifications and Example:

NFPA standard is for identifying the location of the Fire Alarm Control Panel (FACP).

NFPA 72 3.3.99 Fire Alarm Control Unit. (FACU or FACP)

A component of the fire alarm system, provided with primary and secondary power sources, which receives signals from initiating devices or other fire alarm control units, and processes these signals to determine part or all of the required fire alarm system output function(s)

Rooms containing the "Fire Alarm Control Panel" should have identifying signage with white reflective letters on a red background, and should be permanently attached to the interior of the door of the Sprinkler Riser Room, at normal eye level.

The sign should be mounted on the door leading to the fire alarm control panel(s) unless otherwise approved by the Office of the Fire Marshal.

Note: The Fire Marshal will determine what the sign says as well as the size of sign needed and may include specific requirements. These requirements should be provided to the Marketing department through [brandapproval@com.edu](mailto:brandapproval@com.edu) who will assist with the design and sign production.

With the Fire Marshal's approval, FACP signs will maintain a consistent look throughout COM facilities (ideally using a red background with white lettering).



Example: Fine Arts Building

Back of House signage identify rooms for Facility employees only or other authorized staff.

Fire Alarm Control Panel (FACP) signage (color, size, etc) will be determined by the Fire Marshal. Based on those parameters, the Marketing office will assist with the sign's design creation, brand approval and production assistance.

All campus and building signage (including interior, exterior, permanent or temporary) created by internal staff or external parties must be submitted as proofs to the Office of Marketing and Public Affairs for brand approval prior to printing, production, distribution and installation:

[brandapproval@com.edu](mailto:brandapproval@com.edu)

# Campus Signage Interior Wayfinding Directionals: Egress Map Plaques

## Egress Map Specifications:

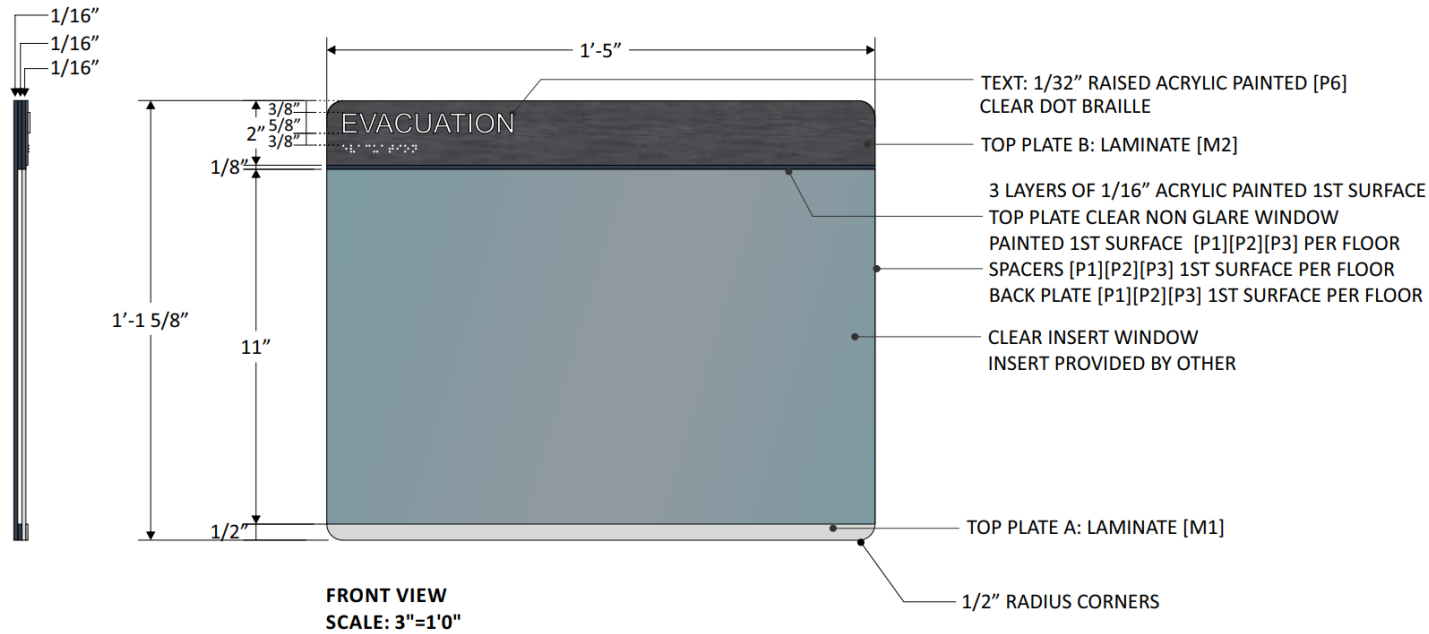

All campus and building signage (including interior, exterior, permanent or temporary) created by internal staff or external parties must be submitted as proofs to the Office of Marketing and Public Affairs for brand approval prior to printing, production, distribution and installation:

[brandapproval@com.edu](mailto:brandapproval@com.edu)

## Accent Stripe Color:



P1

SW 6244  
NAVAL

# Campus Signage Interior Wayfinding Directionals: Elevator Communications

## Elevator Visual Treatment Specifications:

Elevator entrance walls will be painted with Sherwin Williams zero vapor paint in the color Real Red (SW 6868). Floor numbers are written in Roboto Bold, created in white vinyl. Final number height may vary depending on ceiling space above the elevator door and filling the adjacent space in a visually dynamic but cohesive way.

Elevator numeric markings will be consistent on a per building basis and “appear” to be cohesive across campus.

For example, the **Industrial Careers Building** has different ceiling heights on floors 1 and 2. However, all floors in this building use the same 63in H vinyl number with proportional widths.

In the **Student Center**, floors 1 and 2 also have different ceiling heights. However, both floors use an 84in H vinyl number with proportional widths. Both buildings appear to have the exact same treatment.

**Important:** All walls where vinyl treatments will be applied must be painted with zero vapor paint for proper vinyl adhesion.

As a navigational cue and cohesive identity, all elevator facing walls will be painted red using Sherwin Williams, Zero Vapor paint, color Real Red (SW 6868) from floor to ceiling. In addition, a large white vinyl number identifying the floor level will be applied to the right of the furthest elevator. The number will be positioned elevated on the wall with the top of the number cupping the top of the elevator framed entrance. As conditions will vary, the large number will wrap around and be cropped on adjacent walls as needed.

In some instances, such as the Student Center, the elevator is a self contained red wall.

All campus and building signage (including interior, exterior, permanent or temporary) created by internal staff or external parties must be submitted as proofs to the Office of Marketing and Public Affairs for brand approval prior to printing, production, distribution and installation:

[brandapproval@com.edu](mailto:brandapproval@com.edu)

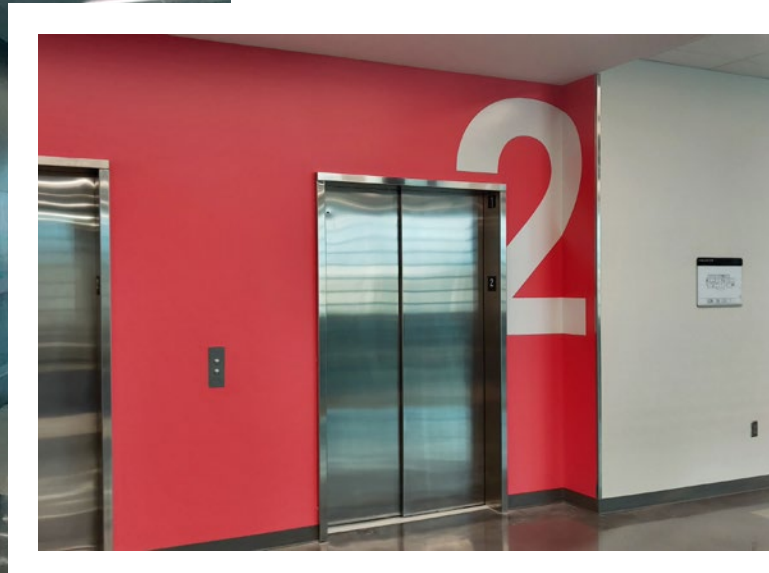

# Campus Signage Interior Wayfinding Directionals: Multi-Floor Floor Directories

**Top text:** CMYK: 70, 64, 63, 64.  
 First line: Roboto Condensed, 43pt, 89pt leading, All caps, 300 tracking, Single line.  
 Second line: Roboto Bold Condensed, 80pt, All caps, -20 tracking, Single line

**"FLOOR" text:**  
 Counterclockwise rotation. Roboto Bold, Light, White, All caps, matches height of the floor number. Gray (CMYK: 0, 0, 0, 30) on non-active floors. White on active floor.

**Large Numbers:** Roboto Bold, White, 267pt

**Non-active floor:** Dark gray panels. CMYK: 0, 0, 0, 85. Program destination text on non-active floors is light gray. CMYK: 9, 7, 7, 0

**Active floor:** Red (where you are viewing the directory) CMYK: 16, 100, 85, 6, all white lettering.

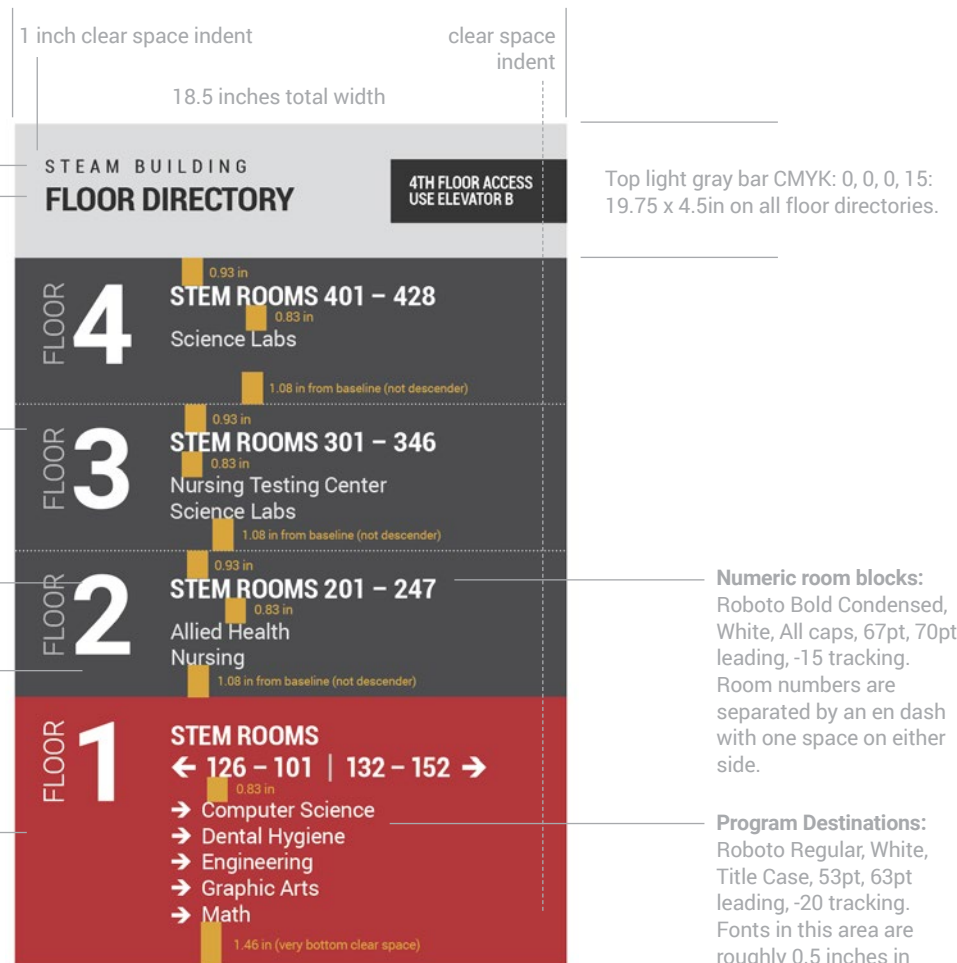

Example: STEAM Elevator B. Floor 1

Yellow areas in design are for measurement references only and are not part of the actual design.

As a location-based feature, only the active floor displays arrows. Right and left arrows are the same height as a non-rounded capital letter.

Floor directories in buildings with one floor will not display floor numbers.

Mount floor directory next to each elevator entrance on every floor of each building (preference to the right of elevator if space allows, otherwise left). It should be mounted a minimum of 12 inches from the wall's edge, or other perceived visual elements such as door frames, wall protrusions, etc.

**Numeric room blocks:** Roboto Bold Condensed, White, All caps, 67pt, 70pt leading, -15 tracking. Room numbers are separated by an en dash with one space on either side.

**Program Destinations:** Roboto Regular, White, Title Case, 53pt, 63pt leading, -20 tracking. Fonts in this area are roughly 0.5 inches in height with readability from at least 5 feet. Non-active floors have destinations written in light gray CMYK: 9, 7, 7, 0.

All fonts, sizes, leading, tracking, color and spacing will be cohesive across all floor directory signage in all buildings.

Floor directory signage will maintain a consistent width of 18.5 inches for all applications and have varying heights per building to accommodate content as needed utilizing specifications noted on the left. Active floors (where the viewer is located) will be displayed in red. Non-active floors are displayed in dark gray.

Floor directories are digitally designed as separate panels for color adjustments, but the final sign is a solid piece of PVC. White dotted lines are used to separate floors but only between floors that have the same color background. For example, there is no dotted line between a floor displayed in red and a floor displayed in dark gray as the color differences visually act as a separator.

All campus and building signage (including interior, exterior, permanent or temporary) created by internal staff or external parties must be submitted as proofs to the Office of Marketing and Public Affairs for brand approval prior to printing, production, distribution and installation:

[brandapproval@com.edu](mailto:brandapproval@com.edu)

# Campus Signage Interior Wayfinding Directionals: Building ID Abbreviations

This chart identifies the Building ID abbreviations students see on their class schedules. For example, a class in the STEAM building would be represented as “STEM” followed by a room number on a student’s class schedule.

Wayfinding signage such as Floor Directories and Numeric Journey Blocks are designed to align with student schedule abbreviations for a cohesive experience. For example, these types of signs display the terminology “STEM ROOMS” on STEAM building wayfinding signage.

Building ID	Description
ADMI	Administration, Bldg. #2
CCC	Com City Centre
CCHS	Clear Creek High School
CONF	Conference Center, Bldg. #21
DKHS	Dickinson High School
FAB	Fine Arts, Bldg. #3
FIR	Firing Range, Bldg. #12
FRHS	Friendswood High School
GYM	Physical Education, Bldg. #4
HHS	Hitchcock High School
ICB	Industrial Careers, Bldg. #23
INT	Internet
LGC	Com League City
LMHS	Lamarque High School
LRC	Learning Resource, Bldg. #8
MNT	College Services, Bldg. #11
PSC	Public Service; Bldg. #18
SFHS	Santa Fe High School
STEM	Steam, Bldg. #22
STU	Student Center, Bldg. #1
TBA	To Be Announced
TCHS	Texas City High School
WLD	Welding, Bldg. #7

All campus and building signage (including interior, exterior, permanent or temporary) created by internal staff or external parties must be submitted as proofs to the Office of Marketing and Public Affairs for brand approval prior to printing, production, distribution and installation:

[brandapproval@com.edu](mailto:brandapproval@com.edu)

# Campus Signage Interior Wayfinding Directionals: Floor Directory Variations

## Example 1: STEAM Elevator A

Active floor highlighted in red displays location-based numbering block and directional arrows with indented current level interest points (since this is a submersive hallway location). Elevator A is a unique situation where it does not access the 4th floor so special instructions are inserted in place of where the 4th floor would typically appear on the sign using "Instructions Bar Gray".

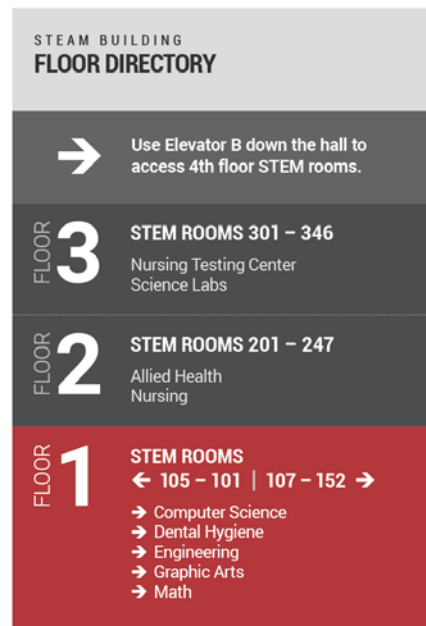

## Example 2: STEAM Elevator B

Active floor highlight shifted to floor 2 displayed in red. The location-based numbering block also shifts to floor 2. Elevator B does access the 4th floor and a small note identifies its use for clarity.

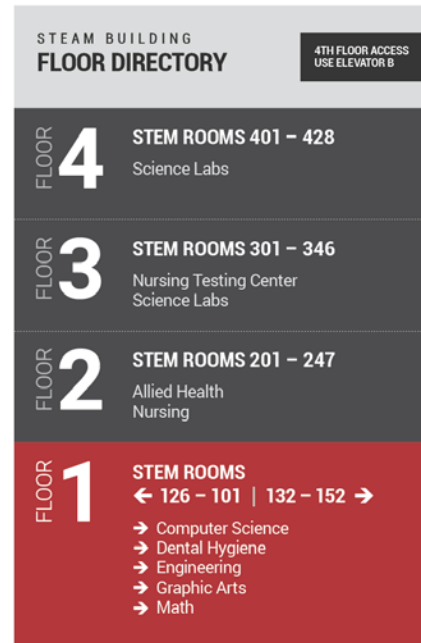

## Example 3: STEAM Hallway Entrance

Active floor highlighted in red. No directional arrows at hallway entrance (as all rooms are ahead in this scenario). At this journey point, elevators are a key point of interest and a (blue) appended Journey Point Sign is included. Note: See appended element specifications on the following pages.

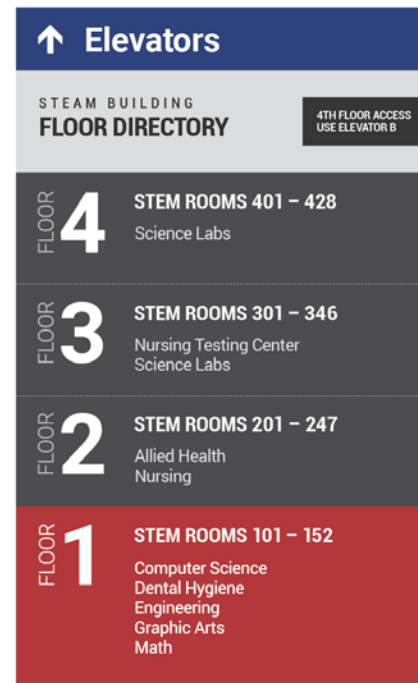

Note, only **active floors** colored in red display Numeric Journey Block elements as a location-based strategy for clarity in wayfinding. This allows the floor directory to double as a directional guidance sign.

Floor directories will have varying content approaches based on their locations. Three variations are shown on the left but these are not all inclusive.

Floor directories will appear on a left or right wall next to an elevator as well as the onset of a hallway entrance on either a (preferential) facing wall, if available, or on one side wall of a hallway entry point. Blue Journey Point signage, for critical wayfinding navigation only, may be appended to the top (in this example "Elevators").

Note: Appended Journey Point signage for Floor Directories has different dimensions than appended Journey Point signage attached to Numeric Journey Block signage.

The Instructions Gray Bar (covered later in this document) is not used with Floor Directories.

All campus and building signage (including interior, exterior, permanent or temporary) created by internal staff or external parties must be submitted as proofs to the Office of Marketing and Public Affairs for brand approval prior to printing, production, distribution and installation:

[brandapproval@com.edu](mailto:brandapproval@com.edu)

# Campus Signage Interior Wayfinding Directionals: Floor Directories: STEAM Elevator Specific Examples

These examples showcase the full set of “elevator specific” floor directories for the STEAM Building. These floor directories illustrate the variations required for Elevator A and Elevator B (as Elevator A does not provide full access. Other floor directories not shown here exist in STEAM at the onset of hallway entrances.

Elevator A: Access to floors 1, 2, 3

STEAM BUILDING FLOOR DIRECTORY	
→	Use Elevator B down the hall to access 4th floor STEM rooms.
<b>FLOOR 3</b>	<b>STEM ROOMS 301 – 346</b> Nursing Testing Center Science Labs
<b>FLOOR 2</b>	<b>STEM ROOMS 201 – 247</b> Allied Health Nursing
<b>FLOOR 1</b>	<b>STEM ROOMS</b> ← 105 – 101   107 – 152 → → Computer Science → Dental Hygiene → Engineering → Graphic Arts → Math

STEAM BUILDING FLOOR DIRECTORY	
→	Use Elevator B down the hall to access 4th floor STEM rooms.
<b>FLOOR 3</b>	<b>STEM ROOMS 301 – 346</b> Nursing Testing Center Science Labs
<b>FLOOR 2</b>	<b>STEM ROOMS</b> ← 215 – 201   215 – 247 → → Allied Health → Nursing
<b>FLOOR 1</b>	<b>STEM ROOMS 101 – 152</b> Computer Science Dental Hygiene Engineering Graphic Arts Math

STEAM BUILDING FLOOR DIRECTORY	
→	Use Elevator B down the hall to access 4th floor STEM rooms.
<b>FLOOR 3</b>	<b>STEM ROOMS</b> ← 307 – 301   307 – 346 → → Nursing Testing Center → Science Labs
<b>FLOOR 2</b>	<b>STEM ROOMS 201 – 247</b> Allied Health Nursing
<b>FLOOR 1</b>	<b>STEM ROOMS 101 – 152</b> Computer Science Dental Hygiene Engineering Graphic Arts Math

Elevator B: Access to floors 1, 2, 3, 4

STEAM BUILDING FLOOR DIRECTORY		4TH FLOOR ACCESS USE ELEVATOR B
<b>FLOOR 4</b>	<b>STEM ROOMS 401 – 428</b> Science Labs	
<b>FLOOR 3</b>	<b>STEM ROOMS 301 – 346</b> Nursing Testing Center Science Labs	
<b>FLOOR 2</b>	<b>STEM ROOMS 201 – 247</b> Allied Health Nursing	
<b>FLOOR 1</b>	<b>STEM ROOMS</b> ← 126 – 101   132 – 152 → → Computer Science → Dental Hygiene → Engineering → Graphic Arts → Math	

STEAM BUILDING FLOOR DIRECTORY		4TH FLOOR ACCESS USE ELEVATOR B
<b>FLOOR 4</b>	<b>STEM ROOMS 401 – 428</b> Science Labs	
<b>FLOOR 3</b>	<b>STEM ROOMS 301 – 346</b> Nursing Testing Center Science Labs	
<b>FLOOR 2</b>	<b>STEM ROOMS</b> ← 225 – 201   226 – 247 → → Allied Health → Nursing	
<b>FLOOR 1</b>	<b>STEM ROOMS 101 – 152</b> Computer Science Dental Hygiene Engineering Graphic Arts Math	

STEAM BUILDING FLOOR DIRECTORY		4TH FLOOR ACCESS USE ELEVATOR B
<b>FLOOR 4</b>	<b>STEM ROOMS 401 – 428</b> Science Labs	
<b>FLOOR 3</b>	<b>STEM ROOMS</b> ← 324 – 301   325 – 346 → → Nursing Testing Center → Science Labs	
<b>FLOOR 2</b>	<b>STEM ROOMS 201 – 247</b> Allied Health Nursing	
<b>FLOOR 1</b>	<b>STEM ROOMS 101 – 152</b> Computer Science Dental Hygiene Engineering Graphic Arts Math	

STEAM BUILDING FLOOR DIRECTORY		4TH FLOOR ACCESS USE ELEVATOR B
<b>FLOOR 4</b>	<b>STEM ROOMS</b> ← 428 – 424   423 – 401 → → Science Labs	
<b>FLOOR 3</b>	<b>STEM ROOMS 301 – 346</b> Nursing Testing Center Science Labs	
<b>FLOOR 2</b>	<b>STEM ROOMS 201 – 247</b> Allied Health Nursing	
<b>FLOOR 1</b>	<b>STEM ROOMS 101 – 152</b> Computer Science Dental Hygiene Engineering Graphic Arts Math	

All campus and building signage (including interior, exterior, permanent or temporary) created by internal staff or external parties must be submitted as proofs to the Office of Marketing and Public Affairs for brand approval prior to printing, production, distribution and installation:

[brandapproval@com.edu](mailto:brandapproval@com.edu)

# Campus Signage Interior Wayfinding Directionals: Floor Directory Placement

Example: STEAM Building, Floor 1, Elevator A



All campus and building signage (including interior, exterior, permanent or temporary) created by internal staff or external parties must be submitted as proofs to the Office of Marketing and Public Affairs for brand approval prior to printing, production, distribution and installation:

[brandapproval@com.edu](mailto:brandapproval@com.edu)



# Campus Signage Interior Wayfinding Directionals: Journey Point Signage

Journey Point Signage  
(destination specific, no room numbers):

## Stand-Alone Journey Point Signage specifications:

**Multi-line continuous text:** Roboto Bold, White, Title Case, 182pt, 218pt leading, -10 to -20 tracking, left-aligned

**Separate journey points:** Roboto Bold, White, Title Case, 182pt, 275pt leading, -10 to -20 tracking, left-aligned

All Journey Point signage utilizes a blue background: CMYK 100, 90, 19, 5

Stand-alone Journey Point signage (not used in conjunction with a Numeric Journey Block sign) will vary in overall dimensions, but font sizes and other details always remain constant (\*specific for stand-alone signage).

It is important to maintain balanced clear space on all sides of text and arrows as shown in examples on this page.

## Appended Journey Point:

Appended Journey point signage is not considered stand-alone. Rather, it is attached to another type of wayfinding such as a Numeric Journey Block or a Floor Directory and has a smaller font size. Learn more on the following pages.

(See Navigational Arrows section in this document for more information on arrows).

Example 1:  
**Stand-alone** Journey Point Sign, Single destination multi-line continuous text



Example 2:  
**Stand-alone** Journey Point Sign Separate journey points



Example 1 in more detail: Clear space and set up. Yellow bars represent simplified distance measurements.



Example 2 in more detail: Clear space and set up. Yellow bars represent simplified distance measurements.



Journey point signage (blue with white lettering) displays the name of a destination and will never include a room number.

This signage maintains standards of blue backgrounds with white lettering, consistent font sizes and navigational arrow placement that always appears to the left of content. Arrow placement and scale requirements should be followed.

Journey Point signage can also be appended to floor directories and Numeric Journey Blocks. Please see other pages in this document for examples.

All campus and building signage (including interior, exterior, permanent or temporary) created by internal staff or external parties must be submitted as proofs to the Office of Marketing and Public Affairs for brand approval prior to printing, production, distribution and installation:

[brandapproval@com.edu](mailto:brandapproval@com.edu)

# Campus Signage Interior Wayfinding Directionals: Numeric Journey Blocks

Numeric Journey Block signs:

- Sign widths: 14 inches wide (always)
- All appended elements will also be 14in wide.
- Sign vertical heights will vary
- Square corners
- Made of PVC
- Located at eye level (approx. 53-60in from floor to top of sign)
- Placed 6 inches from wall edges, hallway corners, door frames or other visual wall disruptions.

When Numeric Journey Block signs appear at a corner wall, for user focus and navigational clarity, the corresponding wall will be painted with a vertical, dark gray stripe (SW Peppercorn) strip 26 inches wide from wall's edge and floor to ceiling. The 14in wide sign will be centered within the stripe with 6 inches on each side. (See image for reference)



Numeric Journey Block with 2 appended elements: Journey Point in blue along the top for the dental community destination, and the Instructions Gray Bar appended at the bottom.

Numeric Journey Blocks (black) are designed for room numbering blocks only.

As needed, they may be appended with notable Journey Point signage elements in blue (along the top) as well as the option for an Instructions Gray Bar (at the bottom).

All campus and building signage (including interior, exterior, permanent or temporary) created by internal staff or external parties must be submitted as proofs to the Office of Marketing and Public Affairs for brand approval prior to printing, production, distribution and installation:

[brandapproval@com.edu](mailto:brandapproval@com.edu)

# Campus Signage Interior Wayfinding Directionals: Numeric Journey Blocks

Numeric Journey Block Signs (the black portion of the sign seen in the image here), designates the building abbreviation as a header (i.e., STEM, ICB, etc.), followed by the word “ROOMS”, and includes location-based blocks of room numbers.

Numeric Journey Block Signs may appear as standalone elements (just the black) or have elements appended to them as needed.

## Numeric Journey Block Sign:

- Always 14 inches wide
- Black background: CMYK: 0, 0, 0, 100
- This sign (black portion) is 14in W x 9.25in H
- Header (i.e., “STEM ROOMS”), white, Roboto Bold Condensed, All caps, 95pt, -15 tracking, single line only, left aligned to left edge of arrows
- Room numbers, White, Roboto Bold Condensed, 145pt, -20 tracking, en dash separator with a blank space on each side
- Arrows always appear along the left side left aligned
- Arrow height aligns with non-rounded capital letter heights (Please see arrow guidelines earlier in this document regarding spacing.)

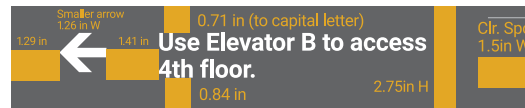
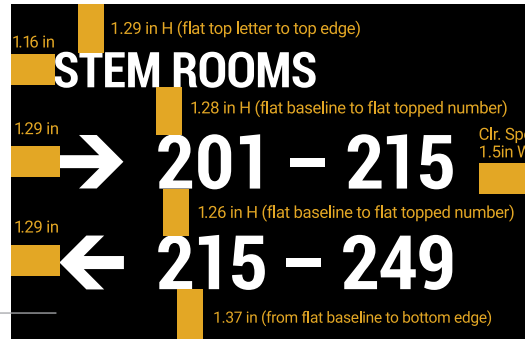

Yellow areas in design visually indicate measurement references only and are not part of the actual design.

Please note: Appended elements (blue and the gray) use a smaller sized arrow as compared to the room number blocks. In this example, the arrow next to “Elevators” and the arrow at the bottom in the Instructions Gray Bar both use the same size arrow that has smaller dimensions than the room number block arrows.

A Numeric Journey Block may be a stand-alone sign (black portion), or have a Journey Point sign (blue) or an Instructions Gray Bar appended, or both appended.

Note: In most cases, elevator usage will not need to be included in the Instructions Gray Bar, nor will they need to be named Elevator A, B, etc. In this gray bar example they are mentioned because Elevator A in STEAM only goes to the 3rd floor while Elevator B goes to the fourth floor.

## Appended Options:

### Appendable Option: “Journey Point Sign” (blue)

- Always 14 inches wide
- Used for community facing destinations or notable journey points
- Blue background: CMYK 100, 90, 19, 5
- Roboto Bold, white, title case, left-aligned, 103pt, 119pt leading, -15 tracking
- Height of blue sign with single line item 2.75in H.
- Height of blue sign with 2 lines of text 4.5in H.

### Appendable Option: “Instructions Gray Bar”:

- Always 14in W x 2.75in H
- Instructions Bar Gray: CMYK: 61, 52, 50, 21
- Roboto Bold, 48pt, white, 52pt Leading, and -10 tracking, sentence case (“Elevator” and letter capitalized)
- Maximum of 2 lines of text in this gray bar area
- If arrow is used, left align corresponding text to the first number in the number block. The white arrow should be positioned centered vertically within the gray band. Two lines of content will be positioned centered vertically within the gray band
- If no arrow is needed in gray bar, then center align text maintaining significant clear space on left and right sides
- A single line of content with an arrow will be vertically centered with the stem of the arrow
- Adequate clear space of at least 1.5 inches along the right side should be maintained

Numeric Journey Blocks (black) are designed for room numbering blocks only. They may appear as singular blocks (one set of room numbers) or double blocks (two rows of room numbers). They may also have elements appended such as a (blue) Journey Point sign on top, or an Instructions Gray Bar along the bottom.

Numeric Journey Blocks are designed using building identification abbreviations found on student class schedules (i.e., STEM, ICB, etc). \*Note: STEAM building classes are noted as “STEM” on class schedules.

All campus and building signage (including interior, exterior, permanent or temporary) created by internal staff or external parties must be submitted as proofs to the Office of Marketing and Public Affairs for brand approval prior to printing, production, distribution and installation:

[brandapproval@com.edu](mailto:brandapproval@com.edu)

# Campus Signage Interior Wayfinding Directionals: Numeric Journey Blocks

Numeric Journey Block "Stand-alone" –  
SINGLE BLOCK.

14in W x 6.25in H



Numeric Journey Block – SINGLE BLOCK with  
Appended Journey Point Element.



Numeric Journey Block "Stand-alone" –  
DOUBLE BLOCK.

14in W x 9.25in H

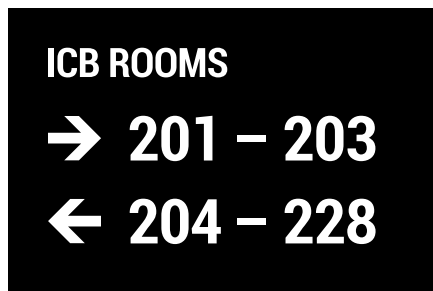

Numeric Journey Block – DOUBLE BLOCK with  
Appended Journey Point Element.

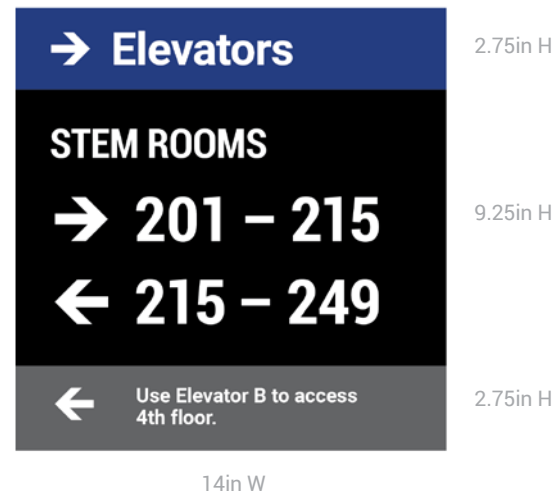

Numeric Journey Block signage (either a single block or double block) can be appended with any number of (blue) Journey Point Signage containing one, two or three journey points placed along the top.

In addition, an Instructions Gray Bar may be appended to the bottom of a single or double blocked Numeric Journey sign.

All campus and building signage (including interior, exterior, permanent or temporary) created by internal staff or external parties must be submitted as proofs to the Office of Marketing and Public Affairs for brand approval prior to printing, production, distribution and installation:

[brandapproval@com.edu](mailto:brandapproval@com.edu)

# Campus Signage Interior Wayfinding Directionals: Numeric Journey Blocks and Appended Elements

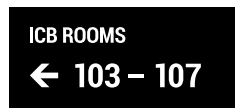

**Example 1:** Numeric Journey Block singular block. Example uses: Side hallway. This sign: 14in W x 6.25in H with 0.25in bleed.



**Example 2:** Numeric Journey Block double block. This sign: 14in W x 9.25in H with 0.25in bleed.

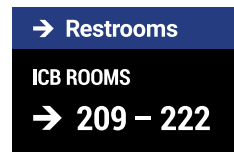

**Example 3:** Numeric Journey Block 14in W x 6.25in H with appended single blue Journey Point 14in W x 2.75in H. Appended journey points at the top with same width (14in) as the Numeric Block. Sign has 0.25in bleed.

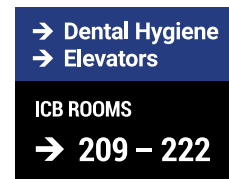

**Example 4:** Numeric Journey Block with appended double line blue Journey Point 14in W x 4.5in H. Maximum 2 lines of text in the top appended area. If more than 2 lines of text, see example 5.

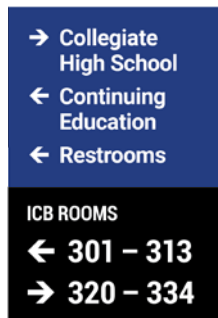

**Example 5:** Numeric Journey Block with appended Journey Point sign showing 3 journey points. Maintains a 14 inch width. Ideally this blue sign should not have more than 3 journey points to avoid overpowerment (they can be single or double lines of text, each will have an arrow on the left only, and the height of the blue sign is flexible to fit content). Clear space should be included on all sides regardless of final sign height.

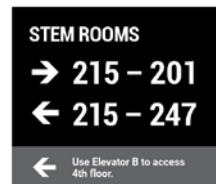

**Example 6:** If the Numeric Journey Block sign requires special instructions, those will be placed succinctly in an Instructions Gray Bar along the bottom of the sign. (A specific gray color is reserved for instruction areas). A smaller arrow is used in this area. A maximum 2 lines of text is permitted in the gray bar maintaining 1.5 inches of clear space on the right (rag) side.

Fonts, font sizes and other font details for each portion of the sign are permanent sizes and must remain consistent with original design specifications.

Appended elements, (blue) Journey Point Signage or Instructions Gray Bar, may be appended to Numeric Journey Blocks that are single or double heights.

All campus and building signage (including interior, exterior, permanent or temporary) created by internal staff or external parties must be submitted as proofs to the Office of Marketing and Public Affairs for brand approval prior to printing, production, distribution and installation:

[brandapproval@com.edu](mailto:brandapproval@com.edu)

# Campus Signage Interior Wayfinding Directionals: Placement of Numeric Journey Blocks

Numeric Journey Block signage (black) should be placed 6 inches from the edge of any adjacent wall.

Numeric Journey Block signage placed at a hallway corner will be placed over a painted gray stripe.

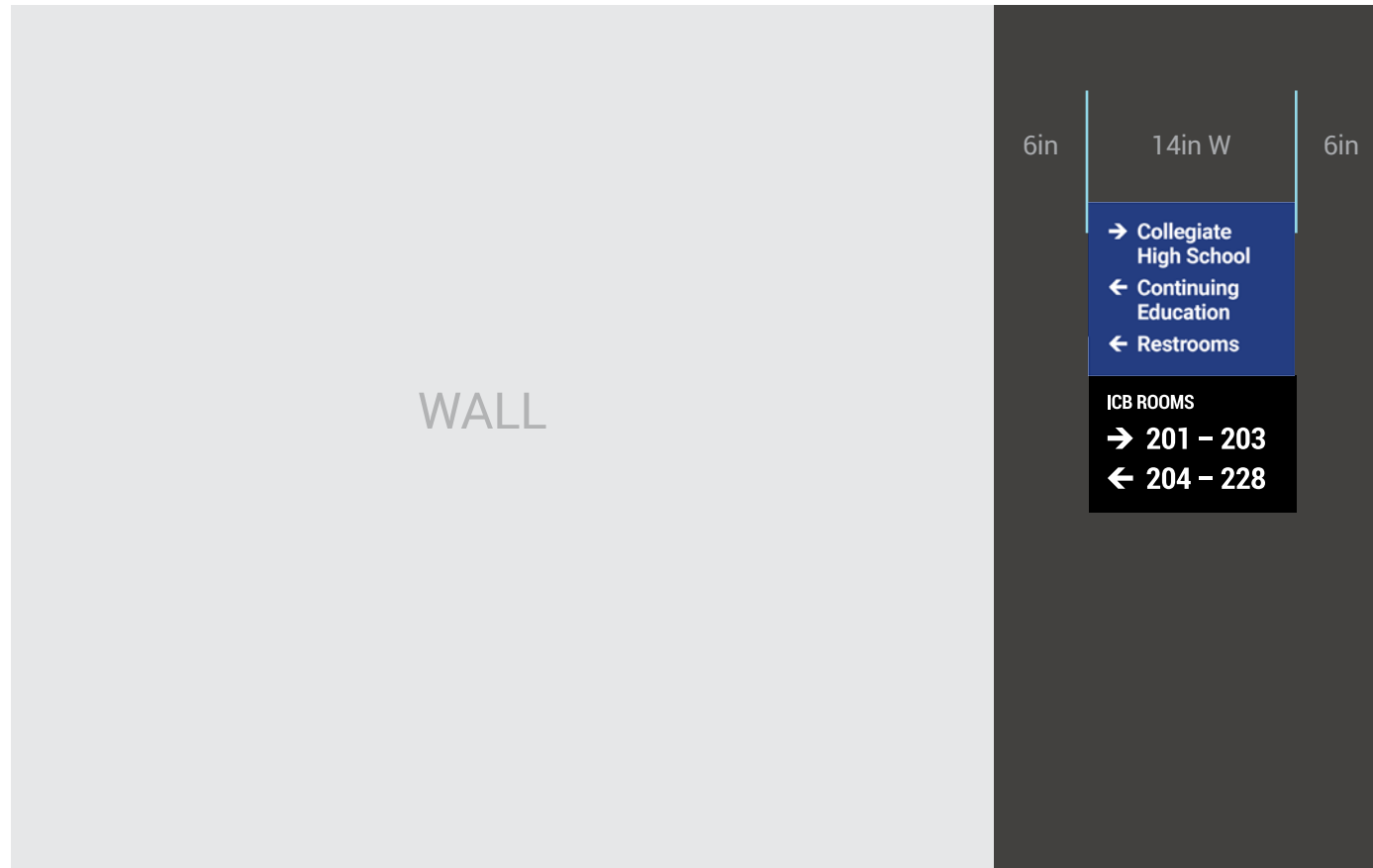

Numeric Journey blocks should be placed 6 inches from any adjacent wall, whether it be a hallway corner, wall protrusion or other visual interruption.

Journey Point signage (blue) that is used in conjunction with Numeric Journey Blocks (black) should maintain an equal width for both signs of 14 inches.

When Numeric Journey Block signs appear at a corner wall, for user focus and navigational clarity, the corresponding wall will be painted with a vertical, dark gray stripe (SW Peppercorn) strip 26 inches wide from wall's edge and from floor to ceiling. The 14in wide sign will be centered within the stripe with 6 inches on each side.

All campus and building signage (including interior, exterior, permanent or temporary) created by internal staff or external parties must be submitted as proofs to the Office of Marketing and Public Affairs for brand approval prior to printing, production, distribution and installation:

[brandapproval@com.edu](mailto:brandapproval@com.edu)

# Campus Signage Interior Wayfinding: Glass Window Vinyl Lettering

## Tier 1:

**Minimum front office glass width requirement: 180in**  
Vinyl Letter Font: Roboto Bold. Title Case. -20 tracking.  
Color: White. Kerning.  
Capital letter height: 10.5in

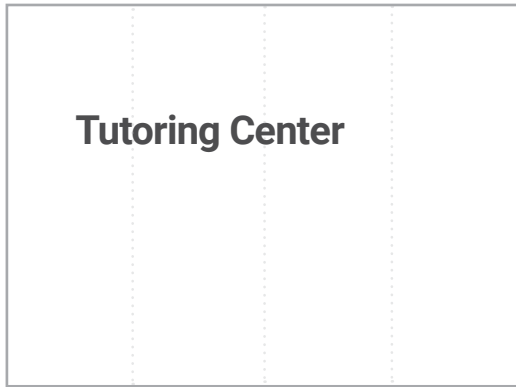

194in

## Tier 2:

**Minimum front office glass width requirement: 145in**  
Vinyl Letter Font: Roboto Bold. Title Case. tracking -20. Kerning.  
Color: White. Capital letter height: 9in

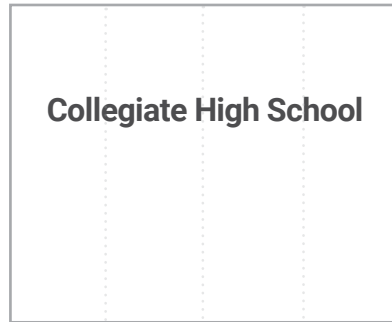

149in

## Tier 3:

**Minimum front office glass width requirement: 80in**  
Vinyl Letter Font: Roboto Bold. Title Case. tracking -20.  
Color: White. Kerning. Capital letter height: 4.5in

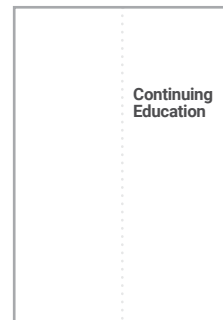

83in

Vinyl lettering applications for all building interior office spaces are divided into three tiers: Tier 1, Tier 2 or Tier 3. These tiers determine the font's scale proportionate to the office window space available to maintain a cohesive experience.

For window vinyl lettering consideration, the office space must:

- 1) frequently be an active community touchpoint or active student-visited location, and
- 2) the office space must fall into one of the three tiers with glass dimensions aligning within one of the designated tiers shown on the left, and
- 3) the office space must be a single department occupancy.

Vinyl installation must account for adequate clear space around lettering including edge of text to edge of window frame. Lettering should be placed on the upper third of the glass frame.

All campus and building signage (including interior, exterior, permanent or temporary) will receive final approval through the Office of Marketing and Public Affairs prior to printing, production, distribution and installation:

[brandapproval@com.edu](mailto:brandapproval@com.edu)

# Campus Signage Interior: Mural Communications

## Wall Mural Specifications:

All vinyl wall murals or vinyl lettering applications require wall pretreatment preparations including wall smoothing to eliminate protrusions or divots of any size and full wall painting prior to mural installation using Sherwin Williams Zero Vapor paint to ensure maximum vinyl adhesion.



Wall mural applications within COM buildings and facilities are strategically designed with considerations regarding building audiences, student success, evoking a positive nature, architectural considerations, color theory, visibility, navigational cues and traffic flows, overall multi-mural cohesiveness, modern and timeless elements, brand alignment, as well as inspirational and motivational impacts.

All vinyl wall murals or vinyl lettering applications require wall treatment preparations including wall smoothing to eliminate protrusions or divots of any size and full wall painting using Sherwin Williams Zero Vapor paint to ensure maximum vinyl adhesion.

All building murals and other facility wall or window treatments are designed and approved by the Marketing department.

Questions? Email [brandapproval@com.edu](mailto:brandapproval@com.edu)



# Campus Signage Interior: Temporary Notices

**Correct display of office notices** with use of a suction cup holder to post office notifications and hours to a glass window.



**Incorrect use:** Taping signage (i.e., flyers, notices, etc) to any facility walls, elevators, doors, glass windows or other surfaces is not permitted.



To maintain a professional appearance throughout COM facilities while avoiding damage to walls and painted surfaces, no signage or advertisements (including flyers, posters, notices, office hours, club materials, etc.) may be applied with tape, adhesives or other forms of tacking directly to any facility walls, doors, elevators, glass windows or other surfaces.

Marketing approved advertising materials may only be hung on designated bulletin board surfaces or placed on lobby area tables including waiting area tables on the first and second floor of the Admin building, or the Amoco Student Commons area on the first floor of the STEAM building. Materials should be removed after their expiration.

Office locations interested in posting hours or notifications on glass windows should use a suction cup based approach as shown on the left.

Please note, all materials hung or distributed at the College of the Mainland campus, or its external facilities, must either be official approved COM marketing-produced materials or COM specific club materials.

Distribution of unapproved non-COM materials within college property is not permitted.

# Signage: Interior

Unique Building Applications

# Campus Signage Interior Wayfinding: Unique Applications

## 4in X 4in Marker Plate Specifications:



STEAM building example:

**Important:** Per building instance, elevators should be named using letters (i.e., “Elevator A”, Elevator B”, etc.) as opposed to “Elevator 1”, etc. to avoid confusion with wayfinding regarding numeric floor levels.

## Multi-Elevator Identification Plaque Specifications:

These are used in situations where it is important to differentiate elevators. For example, in the STEAM Building, Elevator B goes to the fourth floor while Elevator A only goes to the third floor.

- Total sign size: 7in W x 9.25 H
- Location: Wall mount to the left of elevator door.
- Sign top edge position – Marketing discretion.
- Background Upper portion color: CMYK 0, 0, 0, 100
- Background Lower portion color: CMYK 0, 0, 0, 75
- Text “ELEVATOR”: Roboto Bold, 87.56pt, tracking -11, all caps, white, centered and left-aligned
- Text letter identifier “A”, “B”, etc.: Roboto Bold, 346pt, all caps, white, left-aligned
- Text description “All floor access”: Sentence case, white, left-aligned, font: Roboto Bold, 35pt, leading 42pt, tracking 0

Example A



Example B



Lower gray area is only used for elevator-related directional instructions. All elevator plaque identification will display “All floor access.” in the bottom gray band (See example B) unless other descriptive criteria is required (See example A). In the event the description text must be longer, the sign’s dimensions can be extended down, but all text must maintain its original font size and left-alignment for a cohesive appearance with other signage. Navigational arrows as shown in Example A must maintain its size when used (it may not be shrunk or enlarged).

Elevator communications address individual elevator naming and visual floor designations.

Multi-Elevator plaques are only displayed in buildings where more than one elevator exists on the same floor but elevators serve a different purpose (i.e., a specific elevator reaches a level the other does not). Plaque identification will be white lettering over black and medium gray signage.

**Important:** Per building instance, elevators should be named using letters (i.e., “Elevator A”, Elevator B”, etc.) to avoid confusion with wayfinding regarding numeric floor levels. This includes 4x4in elevator plates. This is especially critical where more than one elevator exists in a particular building with multiple floors (i.e., STEAM).

All campus and building signage (including interior, exterior, permanent or temporary) created by internal staff or external parties must be submitted as proofs to the Office of Marketing and Public Affairs for brand approval prior to printing, production, distribution and installation:

[brandapproval@com.edu](mailto:brandapproval@com.edu)

# Signage: Vehicular

# Campus Signage: Vehicular

The COM marketing office manages branding of all college vehicles bearing the college logo, written college name "College of the Mainland" and other college seals including Public Service Careers vehicles.



Campus vehicles bearing the college brand must also follow logo usage requirements detailed in these guidelines.

Logo placement should include clear space around the logo without any automotive design elements (both vehicle indentions/extrusions, or other visual elements) encroaching or invading the logo's clear space.

The color choice of the COM logo used should also compliment and visually align with the color of the vehicle.

Vehicles requiring the college name or a COM logo should submit a request to [brandapproval@com.edu](mailto:brandapproval@com.edu)

# **Brand Campaign:** Be Bold. Fly High.

# Brand Campaign: Be Bold Fly High Logotype Lockups

College of the Mainland's brand campaign, "Be Bold. Fly High." reintroduces the next chapter of the college. New buildings. New programs. Elevated learning experiences and a fanatical commitment to student success.



LOGOTYPE SETUP: ROBOTO BOLD CONDENSED, ALL CAPS  
FONT SIZE: 113.5 PT. LEADING: 98.5 PT. TRACKING: -20

OPTIONAL: LIGHT VARIATION BLUE HORIZONTAL BAND USED IN CONJUNCTION WITH DOMINANT DARKER BLUE, ACTING AS A SUBLEVEL ELEMENT FOR VISUAL SEPARATIONS IN AD LAYOUT.

There are two variations of the Be Bold lockups and messaging.

**"Be Bold. Fly High."** is used for general branding. The goal is to keep the message concise, bold and easy to remember. For billboards and shirts, where you want to make an immediate and lasting impression, simplicity is key. This broader message is designed to inspire, build recognition and reinforce the brand identity without requiring an immediate call to action.

**"Be Bold. Fly High. Join the Flock."** is used in targeted outreach and advertising. Adding "Join the Flock" for more targeted campaigns follows best practices in branding by including a specific call to action. In outreach and advertising, you often want to invite the audience to engage in a more personal or direct way, and "Join the Flock" creates a sense of community and belonging while nudging the audience to take the next step (e.g., enrolling or engaging with the College). It's more actionable, which is exactly what's needed for direct marketing.

# Brand Campaign: Be Bold Fly High Examples



All campus and building signage (including interior, exterior, permanent or temporary) created by internal staff or external parties must be submitted as proofs to the Office of Marketing and Public Affairs for brand approval prior to printing, production, distribution and installation:

[brandapproval@com.edu](mailto:brandapproval@com.edu)



# **Branding:** Clubs and Organizations

# Clubs, Student Organizations and Organized Groups



All student club and organization logos that would like to use the words “College of the Mainland” in their logo require the logo’s design to be created fully by the Marketing department.

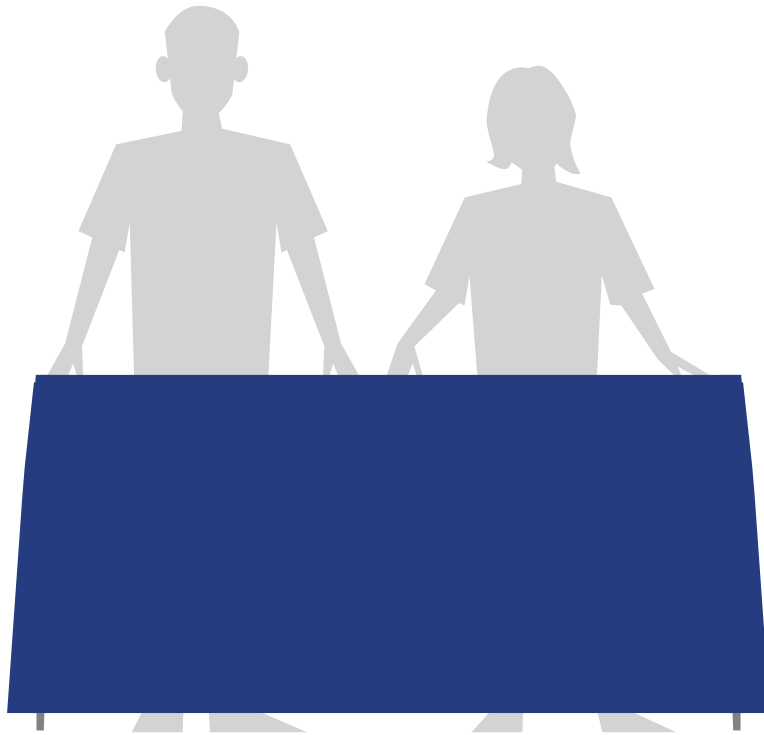

#### PLEASE NOTE:

If an individual or group is interested in creating a group shirt (like their family or friends are going to DisneyWorld and they’re all wearing matching shirts), and it is completely reserved for their personal lives, and they are in no way attempting to represent themselves as an affiliate of COM, an official COM department, an approved partner, program or club or other entity that shows intention of commercial affiliation, then they are free to write the words “College of the Mainland” on their shirts along with their group name (i.e., “50 plus photography team”, etc.). This will not require a review and brand approval from the Marketing department. Please note, official COM logos are not permitted for use.

The key words here are “use for their personal lives.”

Student clubs and organizations are often interested in logos to visually represent themselves. These clubs and organizations are free to design their own logos.

The word “Club” can be used, but is no longer required as part of a club’s or organization’s logo as some may choose to be described as an alliance, association, or other description.

However, if the words “College of the Mainland” are desired as part of a club or student organization logo, then the logo must be created by the marketing department.

All logo designs for clubs and student organizations may not use the official college logo or any modification of the official college logo.

In the rare instance that a logo design requires the purchase of stock imagery, the club or organization requesting this imagery would be responsible for those asset purchases.

Note: Please see information to the left regarding personal use scenarios.

Please contact the COM Marketing office to submit a logo design request or if you have any brand related questions.

[brandapproval@com.edu](mailto:brandapproval@com.edu)

# A Cohesive Brand Experience



These Brand Guidelines illustrate the college's goals to deliver a consistent message on-campus and throughout our community.

Working together to maintain the integrity of our brand we communicate to the world that College of the Mainland is a respected institution of quality and academic excellence.

The Office of Marketing and Public Affairs looks forward to working with you on all of your specific requests. Please reach out with any questions you may have.

---

For more information contact:

College of the Mainland

Office of Marketing and Public Affairs

409-933-8437

[marketing@com.edu](mailto:marketing@com.edu)